

Potenza massima suggerita  
Maximum suggested horsepower  
Puissance maximum suggérée  
Empfohlene maximale Leistung

▶ **70 HP - 51 KW**

	Larghezza totale Total width Largeur hors tout Gesamtbreite
	Larghezza di lavoro Working width Largeur de travail Arbeitsbreite
	Potenza minima suggerita Min. suggested horsepower Puissance minimum suggérée Empfohlene Mindestleistung
	Peso della macchina Weight Poids Gewicht
	Numero di mazze Hammer no. Nombre de masses Anzahl der Schlegel

	VIRGO	VIRGO SE		VIRGO	VIRGO SE		
Mod.	cm	cm	cm	HP / KW	Kg	cm	Nr.
<b>150</b>	166	194	150	40/29	530	540	12
<b>165</b>	181	209	165	45/33	555	565	14
<b>180</b>	196	224	180	50/36	575	585	16



www.celli.it

**VIRGO**  
**VIRGO SE**

**Jens Lubeck**  
Agro ApS

Østergade 65

9560 Hadsund

Telefon 70 70 76 39

info@jenslubeck.dk

**TRINCIATRICE LATERALE**  
**SIDE MULCHER**  
**BROYEUR D'ACCOTEMENT**  
**SEITENMULCHGERÄT**



**Disponibile anche con scatola esterna**  
**Also available with outer gearbox**  
**Disponibile aussi avec boîte extérieure**  
**Verfügbar auch mit Außengetriebe**

*Adatta per manutenzione di fossi, bordi stradali, prati e giardini*  
*Suitable to clean ditches, road shoulders, meadows and gardens*  
*Adapte pour l'entretien des fosses, bords de routes, jardins*  
*Geeignet für Strassenränder, Gräbe, Wiesen und Gärten*

## SPECIFICHE TECNICHE

- potenza massima: 70 HP (51 KW)
- presa di forza: 540 giri/min 1V: 2454 giri/min velocità periferica 43 m/s
- trasmissione a 3 cinghie
- attacco a tre punti fisso categoria 2 con snodo autolivellante
- controcotelli fissi doppi
- scatola con dispositivo di ruota libera
- slitte laterali e rullo posteriore (Ø 133 mm) per regolazione taglio
- spostamento laterale ed inclinazione tramite martinetti idraulici
- rotore (Ø tubo 108 mm) con mazze lisce (Ø 336 mm)
- piede di appoggio
- cardano senza organo di sicurezza

## ACCESSORI A RICHIESTA

- Cardano omocinetico
- Coltelli a squadra
- Mazze dentate

## TECHNICAL SPECIFICATIONS

- maximum horse power: 70 HP (51 KW)
- rotor speed: 2454 rpm (for 540 rpm PTO) Tip speed 43 m/s
- side transmission with 3 belts
- three point hitch cat. 2 with self aligning hinge
- fixed double counter-blades
- gearbox with freewheel safety device
- side skids and rear roller (Ø 133 mm) for cutting height adjustment
- side-shift and tilt (angle) adjustment with hydraulic rams
- rotor (pipe Ø 108 mm) with flat hammer (total Ø 336 mm)
- foot stand
- drive shaft without safety device

## OPTIONAL ACCESSORIES

- Drive shaft with wide-angle yoke
- L shaped blades
- Toothed hammers

## SPECIFICATIONS TECHNIQUES

- puissance maximum: 70 CV (51 KW)
- prise de force 540 t/mm vitesse du rotor: 2454 t/mm vitesse périphérique 43 m/s
- transmission à 3 courroies
- 3em point cat.2 avec axe auto nivelant
- contre couteaux double fixes
- boîtier avec sécurité roue libre
- patins latéraux et rouleau arrière (Ø 133 mm) pour réglage de hauteur de coupe
- déport et inclination hydraulique
- rotor (Ø tube 108 mm) avec masses lisses (Ø total 336 mm)
- pied d'appui
- cardan sans sécurité

## SUR DEMANDE

- Cardan homocinétique
- Couteaux équerres
- Masses dentées

## TECHNISCHE EIGENSCHAFTEN

- max. zul. Schlepperleistung: 70 PS (51 KW)
- Zapfwelle: 540 U/min 1-Stufe: 2454 U/min Umfangsgeschwindigkeit 43 m/s
- Antrieb mit 3 Riemen
- 3-Punkt Anhängung Kat.2 mit selbstnivellierendem Gelenk
- starre doppelte Gegenschneide
- Freilaufgetriebe
- Kufen und Nachlaufwalze (Ø 133 mm) zur Schnittregulierung
- hydraulische Seitenausschwenkung und Neigungsverstellung
- Rotor (Ø Rohr 108 mm) mit Glattschlegel (Ø 336 mm)
- Stützfuß
- Gelenkwelle ohne Überlastsicherung

## SONDERAUSSTATTUNG

- Homokinetische Gelenkwelle
- Winkelmesser
- Keilschlegel

### Misure movimento testata Adjustment and dimension of cutting body Dimensions Abmessungen

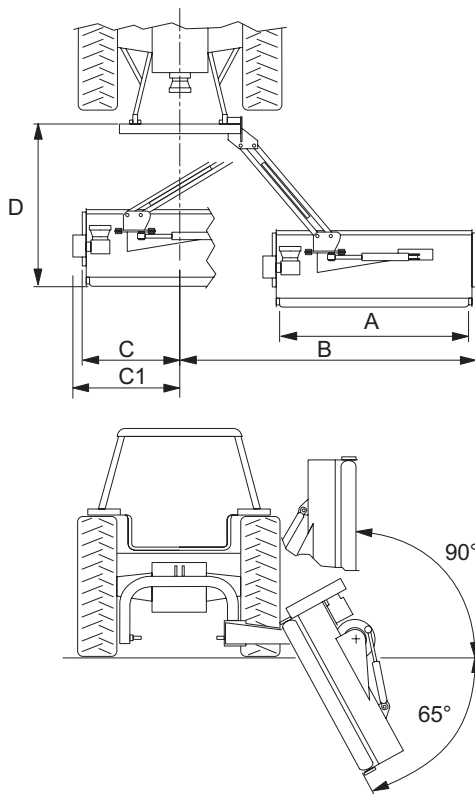

VIRGO	A	B	C	C1	D
	cm	cm	cm	cm	cm
150	150	230	58	69	180/197
165	165	245	58	69	180/197
180	180	260	58	69	180/197

VIRGO SE	A	B	C	C1	D
	cm	cm	cm	cm	cm
150	150	269	19	57	180/197
165	165	284	19	57	180/197
180	180	299	19	57	180/197

