

 **Jens Lubeck**
Agro ApS

Østergade 65
9560 Hadsund
Telefon 70 70 76 39
info@jenslubeck.dk

series RT

ROC





RT 1220

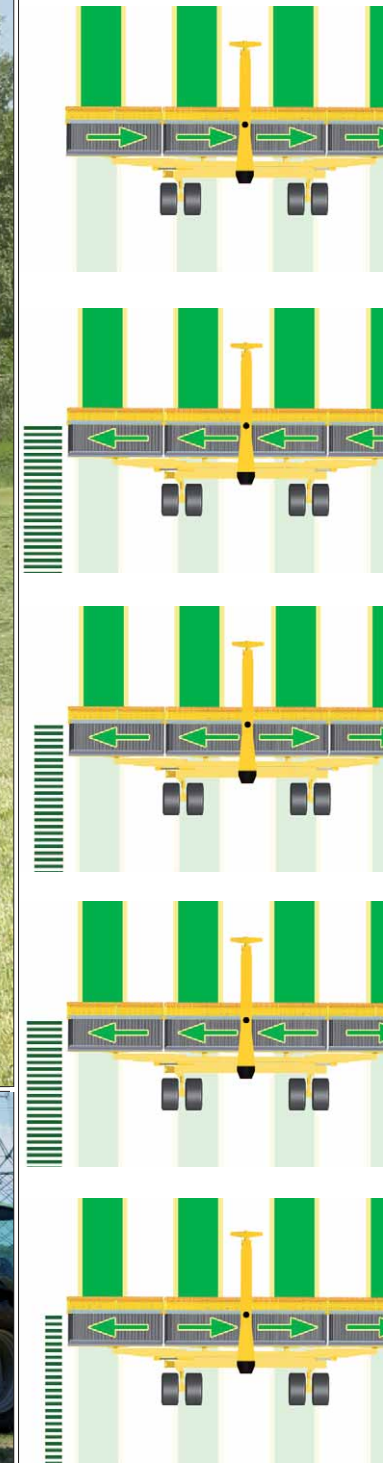

2

3

4



RT 1220

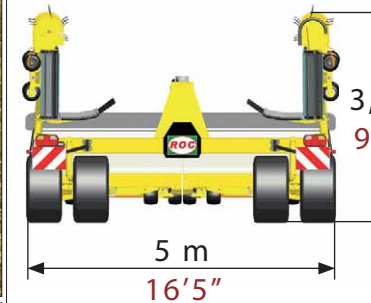
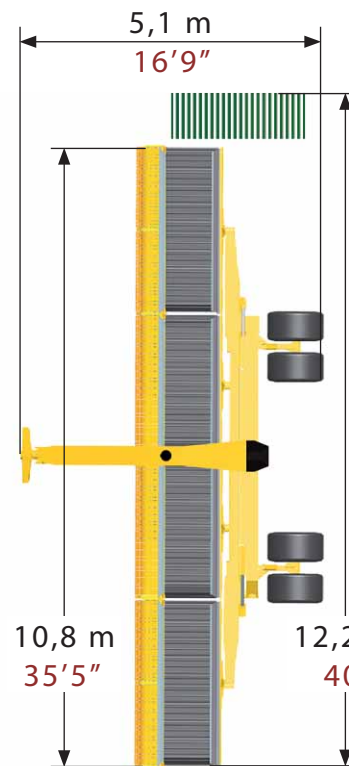

- 520/50 R17
- 5990 kg
13205 lb
- 110 hp min.power
82 kw
- n.5
60 l/min 16 gpm

5

6

7

8



RT 1150

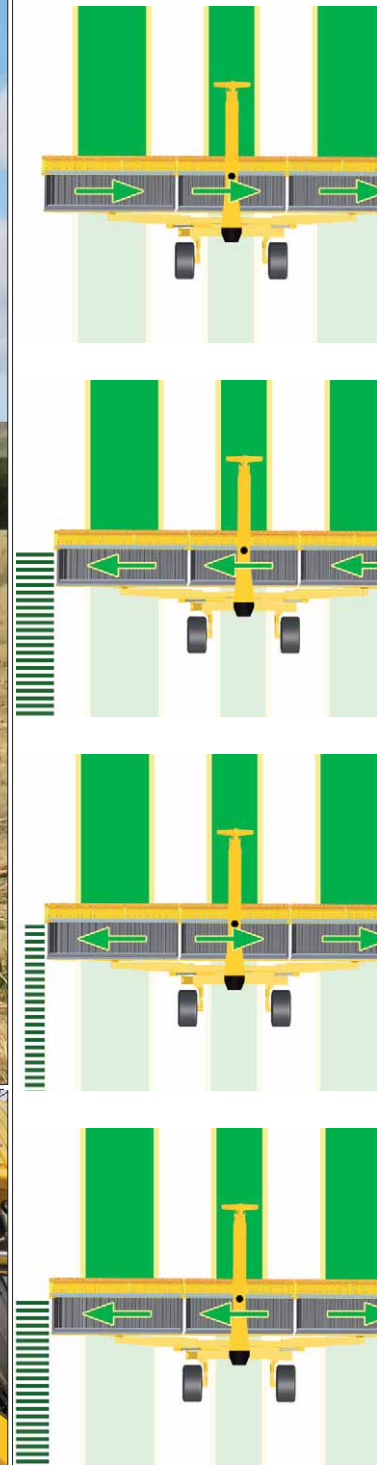



RT 1150

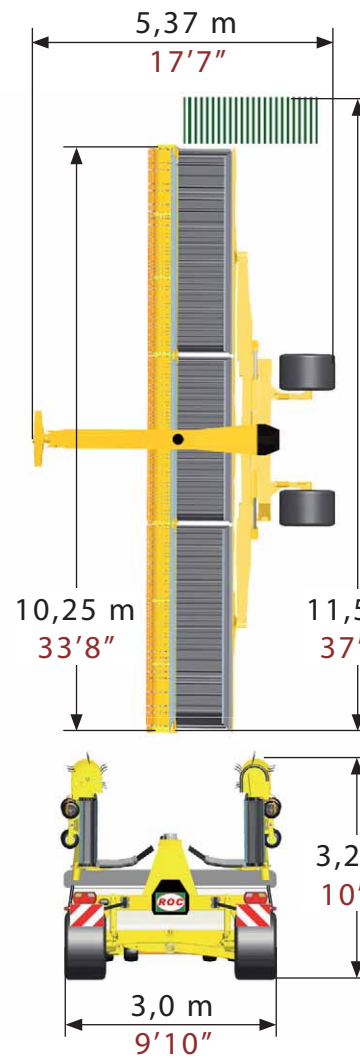

13



14

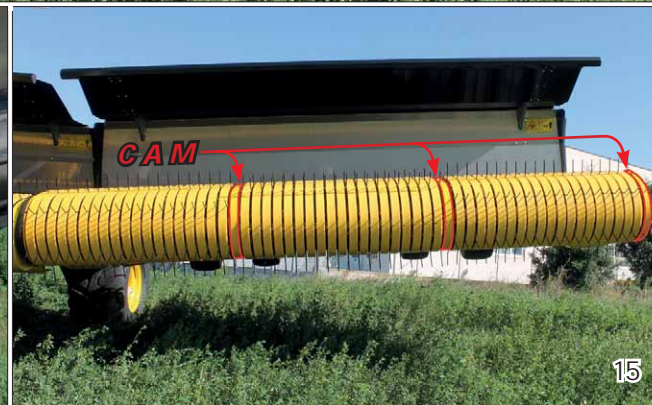

15



16

-  650/40 R22,5
500/45 R22,5
-  6340 kg
13977 lb
- 100 hp min. power
75 kw  n.5
60 l/min 16 gpm



RT 1000

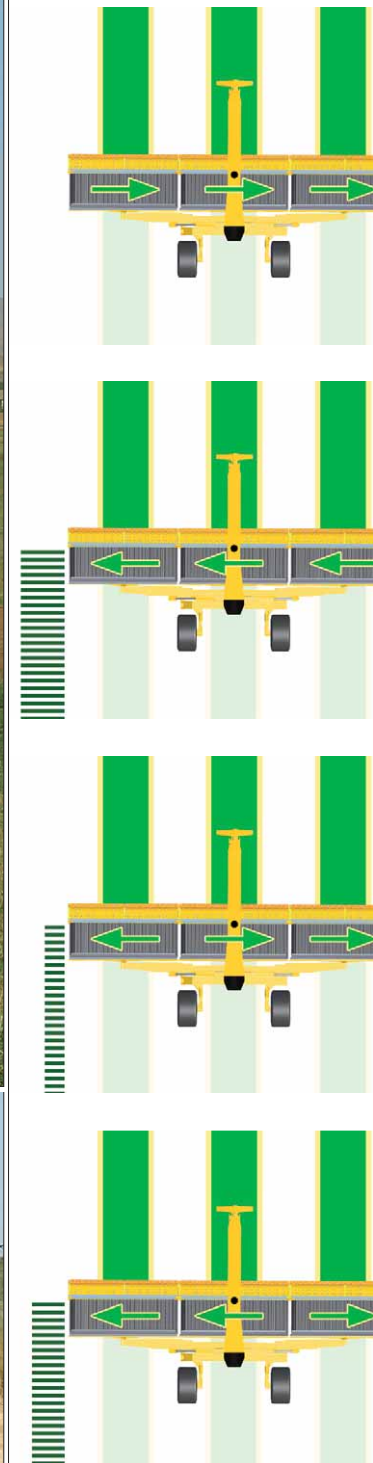

18



19



20



RT 1000

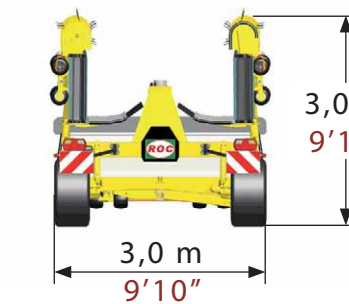
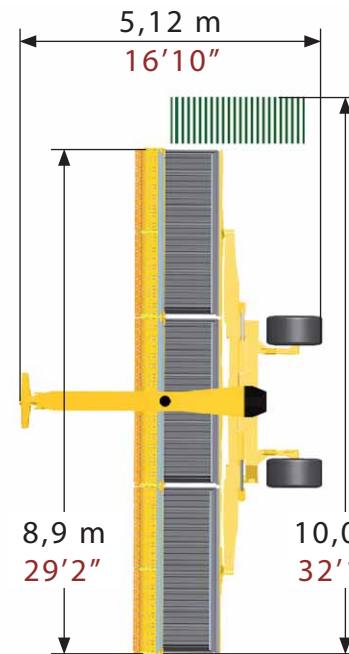

21



22



23



24

-  520/50 R17
-  4980 kg
10980 lb
- 90 hp
67 kw
- min.power  n.5
60 l/min 16 gpm



RT 950



25

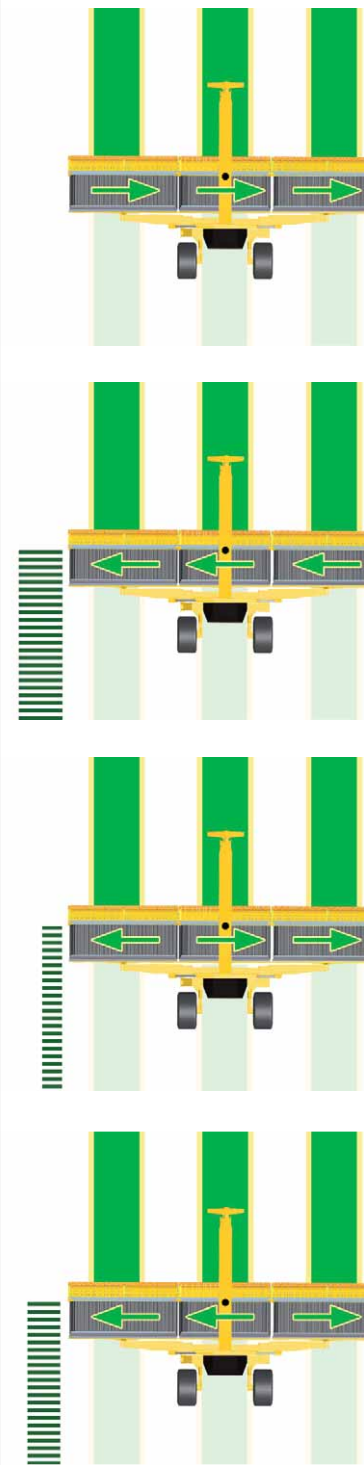

26



27



28



RT 950

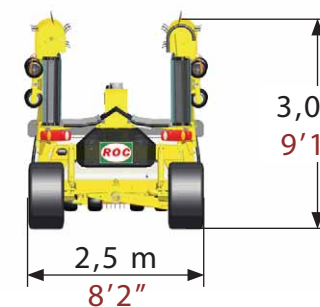
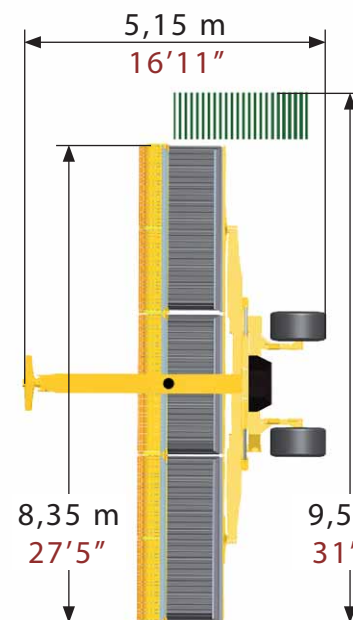

29



30



31



32



520/50 R17



4780 kg
10538 lb

90 hp
67 kw

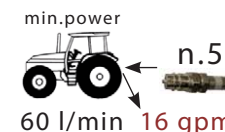



RT 870

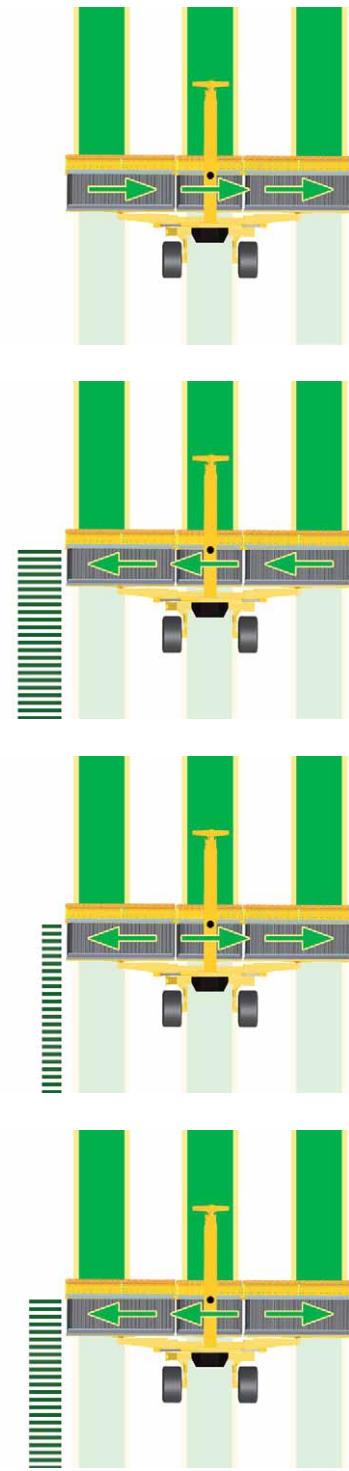

34



35



36

33



RT 870

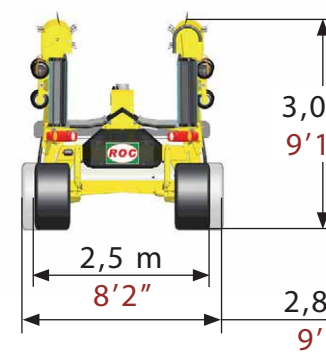
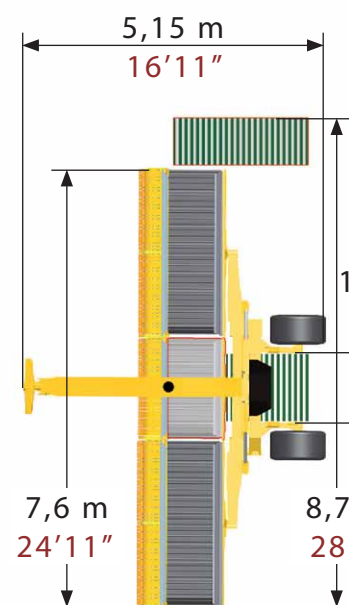

38



39



40

 520/50 R17
15.070 18 148

 4440 kg
9788 lb

80 hp
60 kw

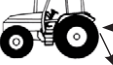
min.power  n.3
60 l/min 16 gpm



RT 870

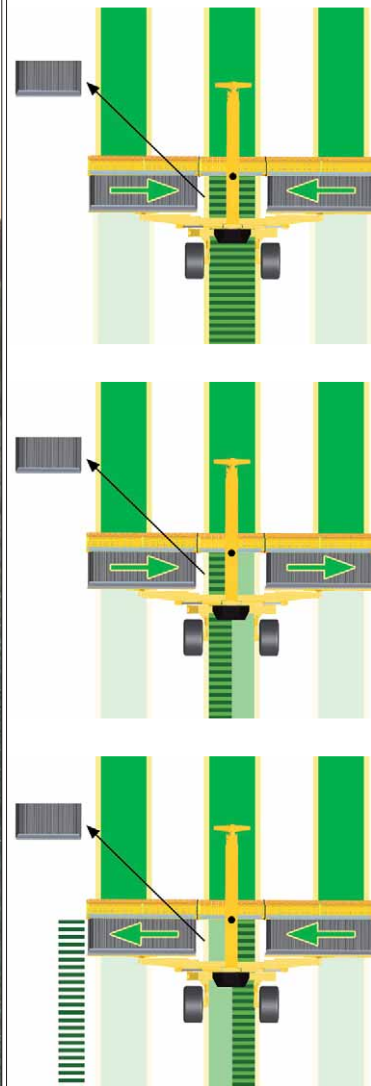

41



42



43





45



46



47

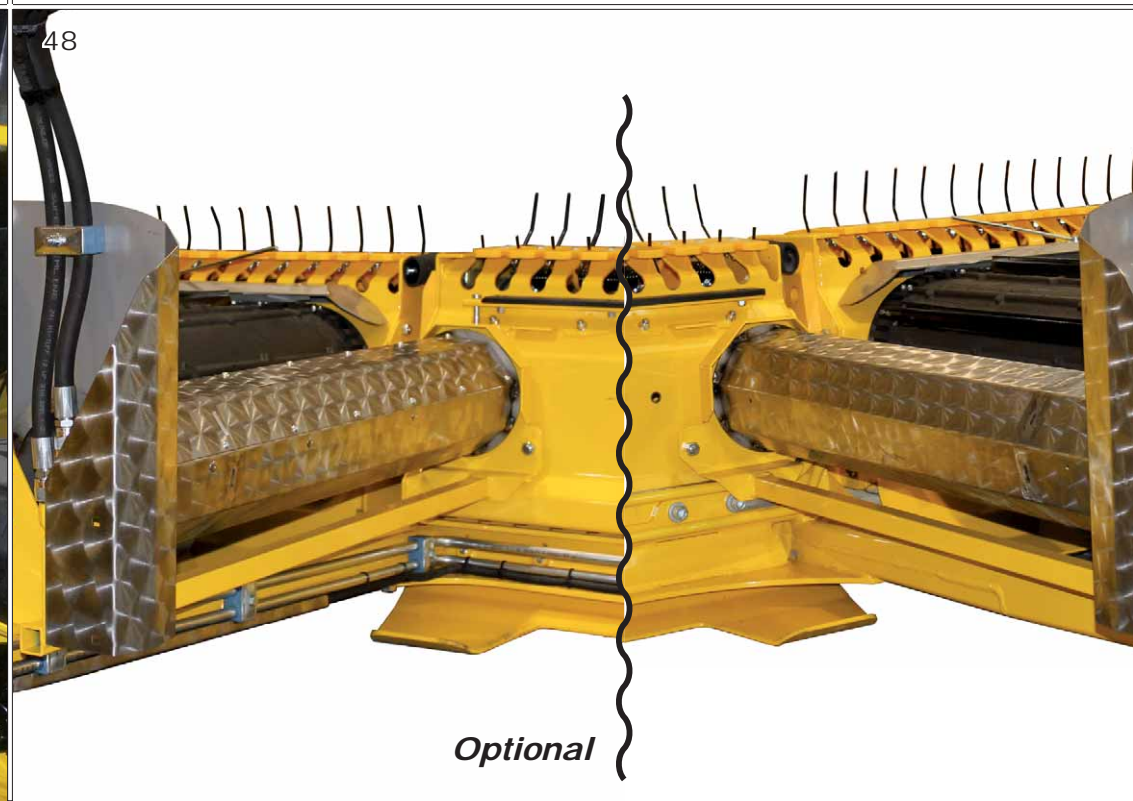

48

Optional



RT 840
RT 840

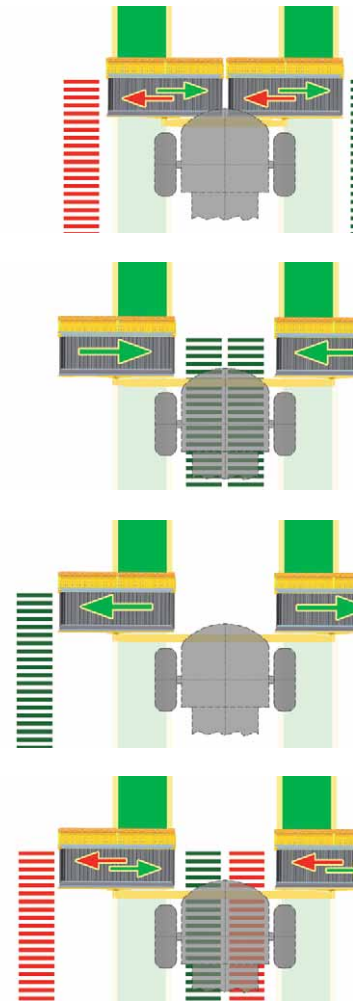

49



50



51





RT 840
RT 840

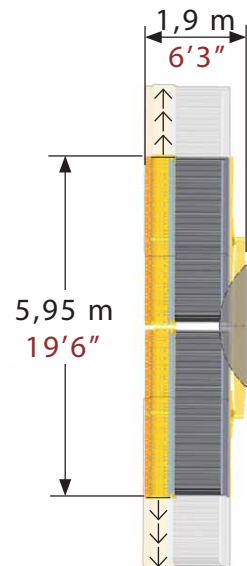
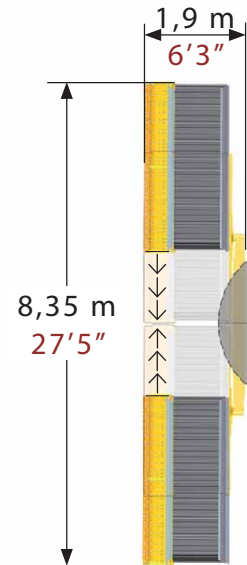

53



54



55



56



2290 kg
5048 lb



RT 880

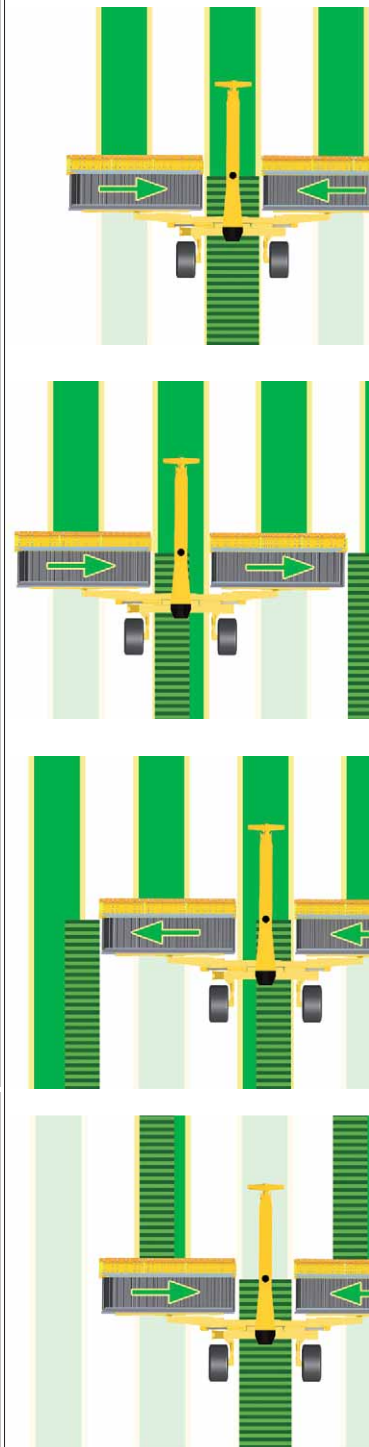

57



58



59



60



RT 880

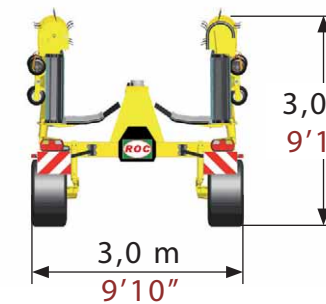
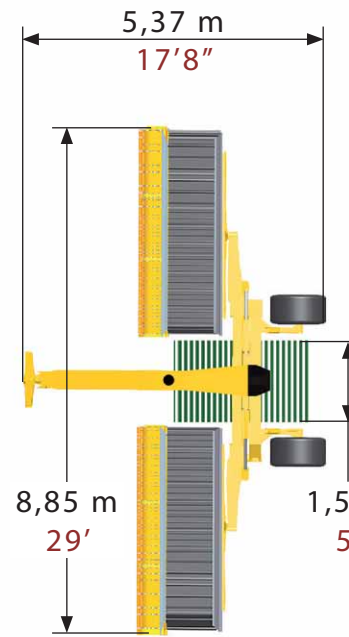

61



62



63



64

-  500/45 R22,
-  4950 kg
10912 lb
- 80 hp
60 kw  ← n.5
min.power



RT 730

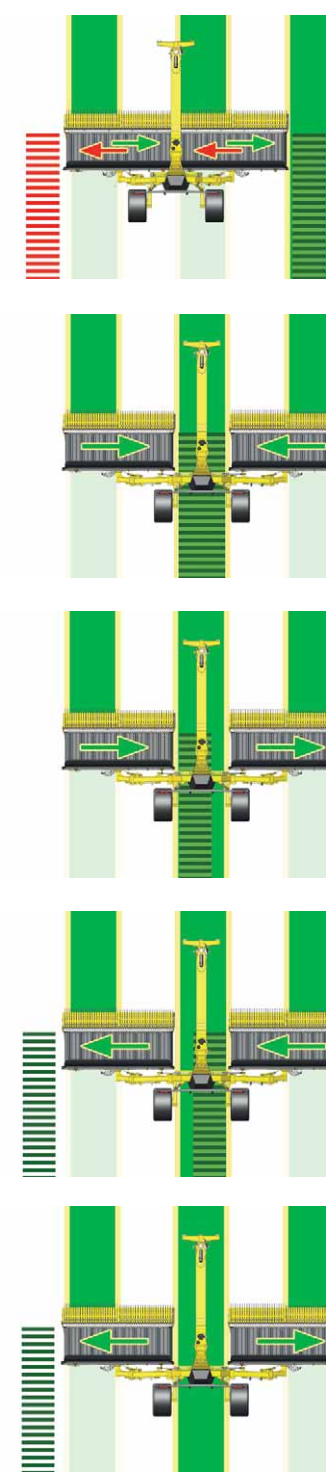

66



67



68



RT 730

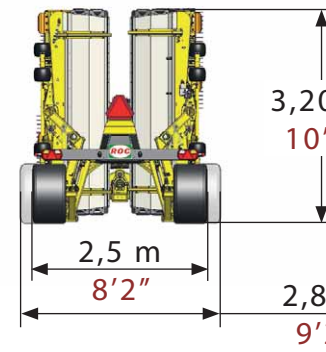
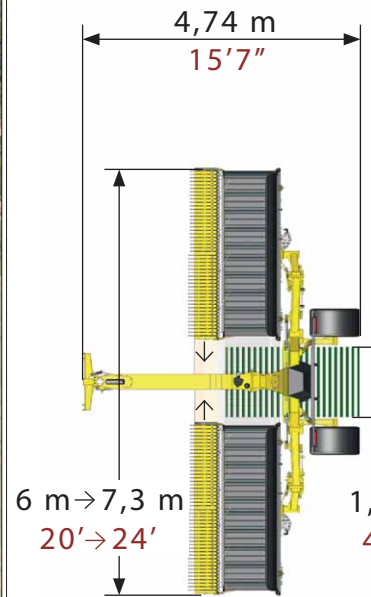

70



71



72

-  480/45 R17
-  3180 kg
7010 lb
- 70 hp
52 kw
- min. power  n.3
50 l/min 13 gpm



RT 630



73

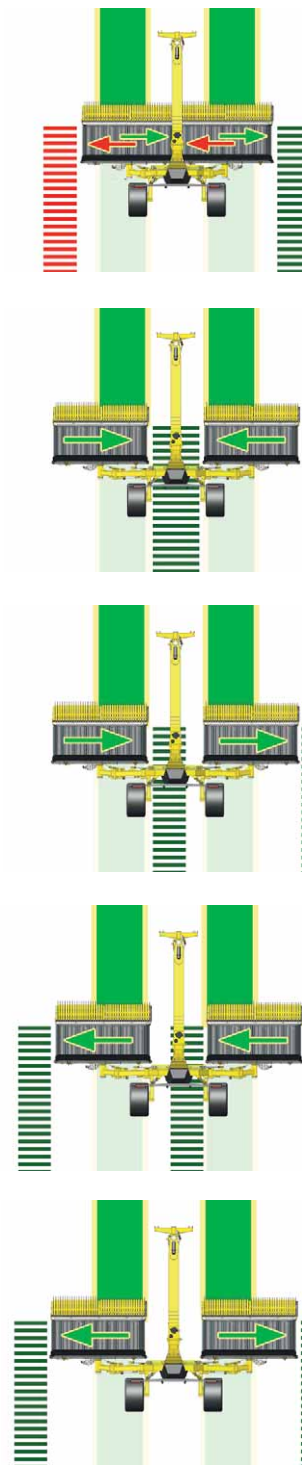

74



75



76



RT 630

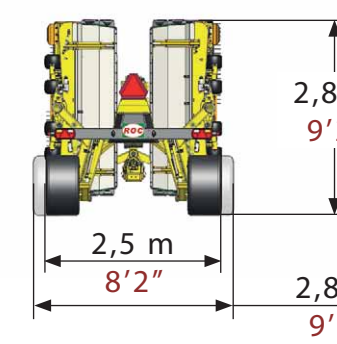
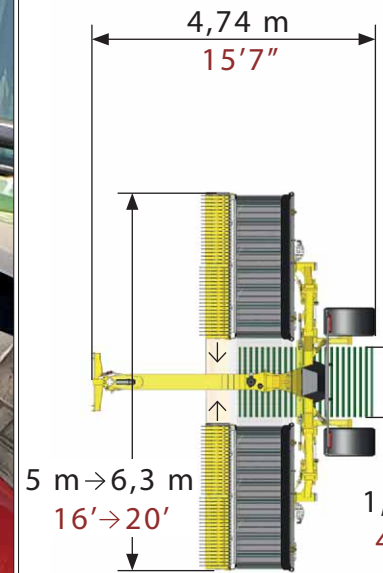

78



79



80

 480/45 R17

 2950 kg
6503 lb

70 hp
52 kw

min. power  n.3
50 l/min 13 gpm



RT 380



81

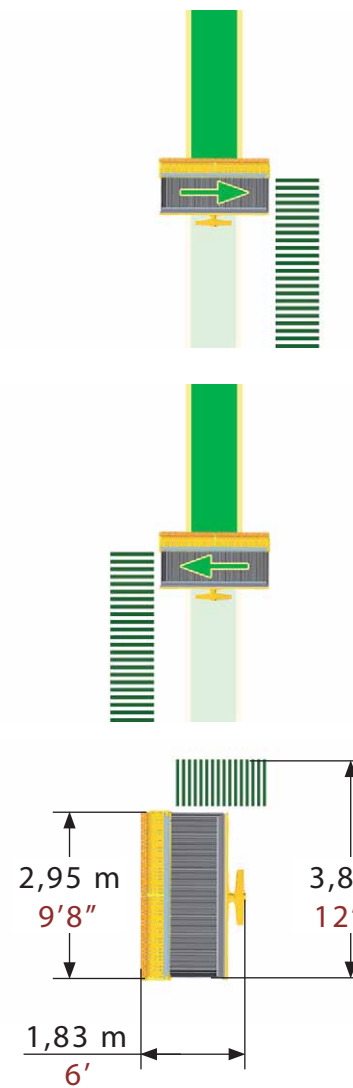

82



83



84



890 kg
1962 lb

60 hp
45 kw



34 l/min 9 gpm

n.3

La serie di raccogli-andanatori ROC RT delinea un sistema rivoluzionario di inghinatura che li rende capaci di andanare il prodotto in maniera delicata mantenendolo pulito e integro anche nelle ore più calde della giornata. Una volta raccolto, il prodotto viene depositato su un nastro trasportatore capace di formare una sola andana soffice lato sinistro, o lato destro, oppure due andane in contemporanea a sinistra e a destra. Questa flessibilità di scarico dell'andana dà la possibilità di depositarla in una zona priva di prodotto per facilitarne l'uniformità nell'essiccazione. Inoltre questo sistema permette di formare andane a grandi distanze fra loro in maniera da garantire sempre una grande quantità di prodotto per le macchine da raccolta, aumentando la produttività. La serie RT garantisce un'elevata qualità di raccolta grazie ai numerosi cilindri idraulici che controllano l'oscillazione, la sospensione e la chiusura degli elementi di raccolta. Inoltre l'RT ha un sistema di sollevamento dell'asse posteriore capace di elevare notevolmente fino a 1m. gli elementi di raccolta, per far sì che possano passare sopra le andane già create a fondo campo. Queste caratteristiche unite alla minuziosa cura dei particolari e al generoso sovradimensionamento di tutti gli organi meccanici e idraulici rendono questa macchina dedicata ad una clientela professionale che esige alta qualità.

La série de ramasseurs-andaineurs ROC RT présente un système de ramassage révolutionnaire. Grâce à ce nouveau système les ramasseurs sont à même de récolter le produit délicatement pendant l'opération d'andainage, tout en garantissant sa netteté et son intégrité même dans les heures les plus chaudes de la journée. Après le ramassage, le produit est déposé sur un tapis-transporteur qui va créer un seul andain côté gauche ou côté droit ou bien deux andains à la fois à gauche et à droite. Cette flexibilité dans le déchargement de l'andain donne la possibilité de le déposer dans une zone privée de produit pour en faciliter l'essiccage de façon uniforme. De plus, ce système permet de former des andains à grandes distances entre eux de manière à garantir toujours une grande quantité de produit pour les machines destinées à la récolte. La série RT garantit une récolte de qualité supérieure grâce aux nombreux cylindres hydrauliques qui contrôlent l'oscillation, la suspension et la fermeture des éléments de récolte. Par ailleurs, le RT présente un système d'élévation de l'axe postérieur capable d'élever considérablement jusqu'à 1 m. les éléments de récolte de sorte qu'ils puissent passer au-dessus des andains déjà créés au bord du champ. Ces caractéristiques, le soin pour le détail et les organes mécaniques et hydrauliques largement surdimensionnés font de cette machine l'atout idéal pour une clientèle qualifiée qui demande de la qualité.

The ROC Continuous Merger Series features a revolutionary three head system which allows for picking up swaths of any width or configuration without being row sensitive. The product is lifted gently while keeping it undisturbedly free of dirt or foreign material. After lifting the product, it is placed on a self-cleaning belt that does not require hourly or daily maintenance. The windrow is left light and fluffy as to promote fast uniform drying. With Harvesting machines increasing in horsepower, the RT series allows you to build windrows of any size depending on the tonnage of the crop by gently re-lifting a windrow that has already been merged and adding it to others for infinite widths, thereby increasing the productivity of your Harvesting Equipment without sacrificing any crop quality. The RT Series Guarantees a High Quality crop thanks to its remarkable suspension system which controls ground pressure and oscillation of all the Pickup Heads as well as the transport wheels. Furthermore, The RT Series has a rear axle lifting system which can lift the remarkable height of 1 m / 3 ft to clear large windrows while turning around the headlands. These features and Special Care for every detail coupled with unsurpassed reliability, performance, and quality leave the RT Series the only real choice for Professionals who cannot afford to compromise their Harvesting operations and crop quality.

La serie de rastrillos ROC RT delinea un sistema revolucionario de ingeniería a tres cabezas que rinde la capacidad de hilerar el producto de forma delicada manteniéndolo limpio e íntegro, también en las horas mas cálidas del día. Una vez recogido el producto va depositado en una cinta transportadora capaz de formar una sola hilera hueca a izquierda, o a derecha, o ambos lados a la vez. Esta flexibilidad de descarga de la hilera da la posibilidad de depositarla en una zona libre de producto para facilitar la uniformidad en la secación. Además, este sistema permite formar hileras de gran distancia entre ellas de manera que siempre garantiza una gran cantidad de producto para los recogedores, aumentando la productividad. La serie RT garantiza una gran calidad de recogida gracias a los numerosos cilindros hidráulicos que controlan la oscilación, la suspensión y el cierre de los elementos de recogida. Por otra parte el RT tiene un sistema de elevación de los ejes posteriores capaces de elevar notablemente hasta 1 m los elementos de recogida, de modo que puedan pasar por encima de las hileras ya creadas al final del campo. Estas características unidas al minucioso cuidado de los particulares hacen que esta máquina esté dedicada a una clientela profesional que exige calidad.

ROC Bandschwader Serie RT verkörpern ein revolutionäres Giroschwader-System. Mit Serie RT wird das Futter sauber und ohne Blattverluste auch bei höheren Tagestemperaturen geschwadet. Über die Pick Up, ausgestattet mit speziellen Zinken, wird das Futter den Förderbändern zugeführt. Durch den hydraulischen Antrieb der Querförderbänder besteht die Möglichkeit den Schwad nach links oder rechts bzw. links und rechts geteilt zu legen. Diese Flexibilität beim Ablegen der Schwade gibt die Gelegenheit, die Schwade in einer futterfreien Zone abzulegen und somit den Anwelkprozess zu beschleunigen. Mit dem System kann auch Futter in größeren Abständen zu einem großen Schwad zusammengeführt werden und dadurch die Leistungsfähigkeit der nachfolgenden Erntemaschine erheblich gesteigert werden. Die hydraulisch gesteuerte Pick Up und Auslegerarme, zusammen mit der mechanischen Federung, garantieren eine sehr gute Boden Anpassung und somit eine saubere Futteraufnahme. Bei der Serie RT kann das Fahrwerk bis zu 1 m angehoben werden, somit können auch große Schwaden bei der Arbeit problemlos überfahren werden. Der Vorteil des ROC Bandschwaders gegenüber normalen Kreiselschwadern ist, dass das Futter nicht auf dem Boden entlang zusammen "gekehrt" wird. Sie haben kein Gewicht, Steine oder andere Fremdkörper im Futter und können dies auch bei hohen TS-Gezeiten schonend und ohne Blattverluste zusammenschwaden. Diese ganzen Details und Besonderheiten machen den ROC Bandschwader RT zu einer Maschine die für eine anspruchsvolle Kundschaft geeignet ist.

يذلل اثنان مثل اس وورل او ذر ك ت ب م ل ا م اظن ل Roc Continuous Merger ة و م ج م ز ر ر
ة ي ض ر ا ل ا ع ق ر ل ا ن م ل ا ك ش ا و ت ا ح ا س م ة ي ا ل د ص ح ل ا س و و ر ه ي ج و ت و د ص ح ب ح م
ا ي ل ا ح ل ظ ي ا م ن ي ب ق ف ر ب ح ت ن م ل ا ع ف ر م ت ي . ت ا س ح م ل ا ب ه و ح م ل ا ق ص ر ا ع ل ا
ي ل ع ع ص و ي ، ح ت ن م ل ا ع ف ر د ع ب . ق د ص ي ا ل ل ك ش ب ق ب ي ر غ ل ا د ا و م ل ا و خ ا س ت ا ل
م و ي ل ك و ا ة ع ا س ل ك ق ر م ت س م ة ن ا ي ص ب ل ط ت ي ا ل ي ذ ل ا ي ت ا ذ ل ا ف ي ظ ن ت ل ل ر
ك ل ح م س ت . ا ه ف ا ف ج ة ع ر س ز ي ز ع ت ل ق ف ر و ف ط ل ب ن ب ت ل ا ف و ف ص ل ك ر ت م
ن ي و ك ت ي ف ، ت ا ك ر ح م ل ل ق د ي ا ز ت م ل ا ق ا ط ل ا ت ا ذ د ا ص ح ت ا د ع م ب ة د و ز م ل ا ، RT ة و
ت ا د ع م ة ي ج ا ت ن ا ي ف ق د ا ي ز م ت ن م و ، ت ا ح ا س م ل ا ن م ي ا ن ا ل د د ع ل ن ب ت ف و ف
ن م ص ت ا م ك . ل ي ص ا ح م ل ا ق د و ج ب ة ي ح ص ت ل ا ا ي ل ا ة ج ا ح ل ا ن و د ك ب ق ص ا ح ل ا د ا ص
م ك ح ت ي ي ذ ل ا ع ا ر ل ا ق ي ل ع ت ل ا م ا ظ ن ل ا ض ف ب ة ي ل ا ع ق د و ج ت ا ذ ل ي ص ا ح م RT ة و
ل ق ن ل ا ت ا ل ج ج ن ع ا ل ض ف د ص ح ل ا س و و ر ع ي م ج ب ي ل ق ت و ط ر ا ل ا ط غ ص ي ف
ن م ن ك م ت ي ي ذ ل ا ي ف ل خ ل ا ر و ح م ل ا ع ف ر م ا ظ ن RT ة و م ج م ل ك ت م ت ، ك ل ذ ق ل ع ق و ا ل
ف و ف ص ف ي ظ ن ت ل م د ق 1/3 م ظ و ح ل م ع ا ف ت ر ا ي ل ا ل ص ت ع ف ر ت ا ي ل م ع ب م ا ي
م ذ ل ع ج ت . ة ي س ا ر ل ا ي ض ا ر ل ا ت ا ح ا س م ي ل ع ا ه ب ي ل ق ت ا ن ا ث ا ق ر ي ب ك ل ا ن ب
ق د و ج ل ا و ، ا د ا ل ا و ، ة ا ف ك ل ا ب ن ر ت ق م ل ا ل ي ص ا ف ت ل ا ل ك ب ص ا ح ل ا م ا م ت ا ل ا و ت ا ز ي
ن ي ذ ل ا ن ي ص ص خ ت م ل ل د ح و ا ل ا ي ق ي ق ح ل ا ر ا ي ت خ ا ل RT ة و م ج م ن م ق و ب س م ل ا
ل ي ص ا ح م ل ا ق د و ج و م د ا ص ح ن ي ب ق ي ف و ت ل ا ن و ع ي ط ت س ي ا ل

Серия валкообразователей ROC RT представляет собой революционную систему по ворошению, что позволяет им производить аккуратное валкование продукта, сохраняя его целостность даже в самое жаркое время дня. После сборки продукт укладывается на транспортерную ленту, которая в состоянии формировать только один мягкий валок с левой или правой стороны, или – же два валка одновременно, с левой и правой стороны. Такая гибкость при выгрузке валка дает возможность его складирования в зоне, где отсутствует продукт, для обеспечения однородности при высушивании. Кроме того, подобная система позволяет формировать валки на значительных расстояниях между собой таким образом, что всегда гарантировать наличие большого количества продукции для подбирающих машин, способствует повышению их производительности. Серия оборудования RT гарантирует высокое качество при сборе урожая благодаря большому количеству гидравлических цилиндров, обеспечивающих контроль колебательного движения, включая управление подвеской и закрыванием подбирающих элементов. Кроме того, серия RT оснащена системой подъема задних осей, которая в состоянии обеспечить значительный подъем, до отметки 1 м, подбирающих элементов, чтобы они могли проходить над уже сформированными валками в конце поля. Эти характеристики, вместе с тщательно ухоженными деталями оборудования и значительным запасом прочности и резервной мощности всех механических узлов и гидравлического оборудования, делают данную машину востребованной клиентами из числа профессионалов, которые рассчитывают на высочайшее качество.

Pásový shrnovac ROC predstavuje revolucní systém se třemi sekcemi, které umožňují sber řádku jakékoliv šířenebosložení bezcitlivosti naveliké řádku. Produkt je jemně zvedán a přitom je neuvěřitelně prostý od nečistot či cizího materiálu. Po zvednutí je produkt umístěn na samocističící pásku, který nevyžaduje hodinové nebo denní údržby. Řádek zůstává lehký a nadržovaný pro podporení rovnomerného sušení. Se stále se zvyšujícím výkonem sklízecích stroju dovoluje shrnovac serie RT vytvórit řádky libovolné velikosti závislé na hmotnosti produktu, jemným premístěním již jednou shrnuté řádku a jeho priložením k ostatním pro vytvoření požadované velikosti řádku. Tím zvýšíte produktivitu sklízecí linky bez narušení kvality materiálu. Shrnovac serie RT zaručuje vysokou kvalitu sbírání pomocí pozoruhodného systému odpružení, který ovládá přítlak k zemi a naklápení jednotlivých sekcí i transportních kol. Návíc má zadní náprava shrnovace zvedací systém, který umožňuje celý stroj zvednout až o 1 m pro zachování netknutí řádku během otáčení nasouvratí. Tyto vlastnosti a speciální péce venovávají každému detailu stroje, spojené s neprekonatelnou spolehlivostí, výkonem a kvalitou, nechávají shrnovac RT jako jedinou skutecnou volbu pro profesionály, kteří si nemohou dovolit delat kompromis mezi operacemi sklízecí kvalitou materiálu.



Corn or sorghum stock

85



Straw

86



Corn stock

87



Grass

88

pick-up-strängläggarna från ROC är en revolutionerande serie maskiner som på ett perfekt sätt plockar upp och lägger ihop alla typer av vallgrödor och stråfoder, bredspridet eller englagt från vilken strängbredd som helst, och till den strängstorlek som man önskar. Materialet lyfts upp skonsamt helt utan att förorenas med jord, sten eller rötter. Efter att materialet plockats upp, transporteras det i sidled på ett självvengörande transportband med ett mycket långa underhållsintervall. Strängen eller strängarna som läggs blir oerhört luftiga och skapar optimala förutsättningar för snabb och effektiv fortsatt torkning innan man kommer med fälthacken eller pressen. Med de ständigt större pressarna, snittvagnarna och maskinerna ställs allt större krav på större och jämnare strängar för att dessa maskiner skall kunna utnyttjas maximalt. ROC RT pick-up-strängläggare gör det enkelt att producera strängar som tillmötesgår dessa krav, oavsett om man skall lägga ihop flera strängar eller om man bara skall lufta en existerande stäng. Maskinen går valfritt att ställa in för strängläggning på höger eller vänster sida, eller om man så vill dela på strängen och lägga strängar på båda sidorna. Det finns dessutom modeller som kan lägga mittsträng - kan eventuellt kombineras med en frontenhet, som räfsar rent framför traktorn. RT-serien garanterar en verkligt hög kvalitativ vallgröda och räfsar helt rent tack vare den genialiska avfjädringen av pick-up-enheterna. Dessa sektioner är individuellt upphängda, med både hydraulisk avfjädring och stötdämpning. Stötdämpning med fjädring under varje sektion, så att maskinen följer terrängen helt perfekt. Dessutom har RT-serien breda hjul och ett transport-system som lyfter upp maskinen till en frihöjd på en meter över marken, vilket gör det möjligt att köra över redan lagda strängar på vändtegen. De här egenskaperna i kombination med en oerhörd precision och hög produktkvalitet, ger en funktionssäkerhet och kapacitet utan jämförelse, vilket gör RT-serien till det enda rätta valet för de verkligt professionella som inte vill kompromissa när det gäller skördekapacitet och kvalitet på den skördade grödan.

ROC-noukinkarhottimen kolme noukinta mahdollistavat karheiden noston ja siirron helpoimalla. ROC-noukinkarhottimella on myös mahdollista yhdistää ja siirtää karheita yhä uudestaan. Näin saavutetaan riittävä karhekkoko ja jouhevät ajolinjat myös tehokkaimmilla korjuukoneilla satotasosta riippumatta. Ainutlaatuinen kevennys-, jousitus- ja vaimennusjärjestelmä ROC:n noukinkarhottimissa takaa laadukkaan rehun olo-olosuhteista riippumatta. Taka-akselin nostojärjestelmä nostaa maavaran maksimissaan korkeuteen. Nämä ominaisuudet sekä lukemattomat muut ainutlaatuiset yksityiskohdat takaavat RT-sarjan noukinkarhottimista ainoan vaihtoehtoisen vaihtoehdon ammattilaisille, joiden tärkeimpiä asioita ovat laatu ja toimintavarmuus.

ROC pick-up riven er en revolutionerende serie af maskiner som perfekt samler ethvert materiale op, bredspredt eller fra skår i enhver bredde uafhængig af eksisterende skår. Materialet løftes skånsomt helt uden at forurene med jord, sten eller rødder. Efter at materialet er løftet, transporteres det på et selvrensende transportbånd med lange vedligeholdelsesintervaller. Skåret efterlades let og luftigt for effektiv tørring og optimal opsamling af presser eller finsnitte. Med stadig større pressere og finsnitte stilles krav om større og jævne strå. Det står for at øget kapaciteten på høstmaskinerne. Med ROC RT pick-up riven kan laves strå som imødekommer dette krav, hvad enten der rives flere skår sammen eller der blot rives i eksisterende skår. Maskinen kan valgfrit køre skår til venstre eller højre side, eller delvis skåret med udkast i begge sider. Der findes tillige modeller som kan danne midterskår som evt. kombineres med en frontenhet, som river rent før passage af traktoren. RT Serien garanterer en høj kvalitets afgrøde og river helt rent takket være den geniale affjedring af pick-up-enhederne. Enhederne er ophængt individuelt og affjedres hydraulisk såvel som støddæmpet. Støddæmpning med fjædring under hver sektion, således at maskinen følger terrænet perfekt. Dessuden har RT serien brede hjul og et transport system som løfter maskinen til en frihøjde på én meter, hvilket gør det muligt at passere skår i forageren. Disse egenskaber sammen med en uhørt præcision og høj produktkvalitet, giver en driftsstabilitet og kapacitet uden sammenligning, hvilket gør RT serien til den eneste rette valg for professionelle der ikke vil gå på kompromis med høst effektiviteten og afgrødekvaliteten.

ROC RTシリーズ刈入れ機は日中の暑い時でも収穫物を清潔かつ損傷なく保つことを可能にした革新的な収穫システムです。刈り取った収穫物はベルトコンベアーに載せられ左右いずれかの側、または同時にそれぞれの側に置くことができます。積み下ろし方向についてこのように柔軟性があるため、均一にするための場所が欠けていても収穫物を置くことが可能です。さらにこのシステムでは長い距離にわたって収穫物を置くことによって刈入れ機の収穫量を確実に増加させ生産性の向上を実現します。RTシリーズは振動、サスペンションおよび収穫動作の停止を制御する多数の油圧シリンダーによって優れた品質の収穫物を保証いたします。そのうえRTは刈入れ対象の高さを1メートルまで引き上げる装置を備えており、これによってすでに農地に積み上げた収穫物を通過することができます。これらの特色が細部にわたる精密な配慮によって機械と油圧装置全体を大きなシステムとして統合しこの機器を品質にこだわるプロフェッショナルなお客様に適合したものとしています。

RT大面积收割机系列是具有革命性的侧向搂草机系列，它可以大面积整体于仔细的耙收产品，并且在当天最热的时段仍然可以运行。产品收割以后将会放在位于机器左侧或者右侧，或者同时左右操作放置在传送机的传送带上。这一灵活的卸载方式可以选择性的将其存放在没有该产品的区域以便均匀的除湿干燥。另外该系统可以允许调节其耙间距以持久保证收割机器的收割产品数量，增加产量。RT系列可以保证其高品质的收割质量主要是因为其拥有很多的液压缸，它们控制着机器的摆动，悬架以及收割部件的闭合。除此之外RT还拥有后轴抬升装置，可将收割部件抬升至离地1米的高度，这样轻松移动越过畦田内未耕的地。这些特征结合其精致的完美细节和超多超大机械和液压部件以满足追求品质的专业客户需求。



Alfalfa seed

89



Miscanthus

90



Wheat

91



No stones in the swath!

Green beans

92

Série de enleiradores/recolhedores ROC RT delinea um sistema revolucionário de colheita que permite uma disposição do produto de forma delicada e a manutenção do mesmo, que permanece íntegro e limpo mesmo nas horas mais quentes do dia. Após a colheita, o produto é depositado sobre uma correia transportadora apropriada para formar somente uma fileira macia à direita ou à esquerda, ou ainda duas fileiras contemporaneamente. Esta flexibilidade de carga da fileira assegura a possibilidade de depósito em áreas desprovidas de produto e proporciona uma secagem uniforme. Além disso, este sistema evita a formação de fileiras a grandes distâncias, de forma a assegurar sempre uma grande quantidade de produto para as máquinas responsáveis pela colheita, aumentando portanto a produtividade. A série RT assegura uma excelente qualidade da colheita graças aos diversos cilindros hidráulicos que controlam as oscilações, a suspensão e o fechamento dos elementos de apanha. Além disso, esta série possui um sistema de elevação do eixo posterior capaz de suspender notavelmente, em até 1 m, estes elementos, de modo que os tratores possam transitar sobre as fileiras já criadas no solo. Estas características, juntamente com a atenção meticulosa dedicada aos detalhes e o abundante sobre-dimensionamento de todos os órgãos mecânicos e hidráulicos, tornam estas máquinas apropriadas para uma clientela profissional, que busca a máxima qualidade.

A série ROC RT ekin toplama ve dağıtma makineleri serisi, ürünün, günün en sıcak saatlerinde bile temiz ve diri kalarak hassas bir biçimde toplanmasını mümkün kılacak yeteneğini kazandıran devrim niteliğindeki yenilikçi yan yatma sistemi yansıtır. Ürün, toplandıktan sonra, hafifçe sadece sol tarafına ya da sağ tarafına ya da eş zamanlı olarak hem sağ hem sol tarafına yığma işlemi için oluşturulan yeteneğine sahip bir konveyör bandı üzerine bırakılır. Yığınların oluşturulmasındaki bu esneklik, ekinin kurutmadaki homojenliği sağlamak için ürün olmayan yerlere daha fazla ürün dağıtma olanağını sağlar. Bu sistem, ayrıca, ekin yığınlarının, ekin toplama makineleri için yüksek miktarlarda ürün sağlayarak yüksek üretim verimliliğini garanti edecek biçimde birerinden uzakta oluşturulmasını sağlar. RT serisi, salınımı, süspansiyonu ve toplama ekipmanlarının kapanmasını kontrol eden çok sayıda hidrolik kontrol elemanı sayesinde yüksek toplama kalitesini garanti eder. RT, ayrıca, toplama ekipmanının tarla zemini üzerinde oluşturulan yığın üzerine erişecek şekilde 1 metre yüksekliğe kadar kaldırabilecek arka ekseninde yer alan kaldırma sistemine sahiptir. Tüm mekanik ve hidrolik aksamın büyük bir dikkatle irdelenmiş detaylarında ve cömert ölçülerinde birleşen bu özellikler, bu makineyi, kaliteyi şart koşan müşterilere adanmış bir makine haline getirir.

Seriya tračnih zgrabljalnikov ROC se ponaša z edinstvenim sistemom treh vrsta, ki omogočajo pobiranje redi katerekoli širine ali konfiguracije, ne da bi to porinilo selektivnost vrste. Zgrabljalniki nežno poberejo pridelek in ob tem poberejo presenetljivo malo umazanije ali tujkov. Po dvigu pridelka se ta razporedi na samoočiščevalnem traku, ki ne zahteva urnega ali dnevnega vzdrževanja. Vse redi so rahle in puhaste, kar zagotavlja hitro in enakomerno sušenje. S spravilnimi vrstami z vedno več konjskimi močmi vam serija RT omogoča oblikovanje vrst različnih velikosti, odvisno od tonaže pridelka; to dosežete tako, da nežno in enovno dvignete vrsto redi in jo združite z drugimi v neomejene širine ter s tem povečate produktivnost vaše opreme za spravilo, ne da bi za to morali žrtvovati kakovost pridelka. Serija RT zagotavlja visokokakovosten pridelek, saj s svojim edinstvenim sistemom vzmetenja nadzira pritisk na tleh in nihanje vseh pobirateljev ter transportnih koles. Poleg tega se serija RT ponaša z dvigovalnim sistemom na zadnji osi, ki se lahko dvigne do višine 1 m / 3 čevljev, za odstranjevanje vrst različnih vrst redi med obračanjem na ozari. Zaradi teh značilnosti in podrobnosti skupaj z neprimerljivo zanesljivostjo, zmogljivostjo in kakovostjo, je serija ROC edina prava izbira za profesionalce, ki si ne morejo privoščiti, da bi ogrozili svojo postopke spravila in kakovost pridelka.

ROC серија трајне спојке представља револуционарни систем са три врсте главе, који омогућава купљење откоса жита без обзира на њихову ширину или конфигурацију терена, док истодобно не мора радити искључиво у редовима. Жељењи производ се нежно прикупља на потпуно се чисти од уплива прашине или каквог другог нежељеног материјала. По купљењу производа, исти се поставља на траку која га сама пречишћава, а не захтева при томе одржавање сваког сепаратора или сваког дана. Откос остаје с леве стране што омогућава брзо и равномерно сушење. Уз овај строј за жетву, не само да се добија да јачи конјских снага, него RT серија омогућава откосе било које величине зависно од тонаже. Откоси се сједињују и могуће је их сакупити у било коју захтевану ширину, чиме се појачава продуктивност ваше опреме за жетву без опасности за квалитет усева. Серија RT гарантује високи квалитет усева, благодарећи невероватном систему суспензије који надзире притисак тла те осцилације глава за прикупљање, као и амортизациона точкава при транспорту. Даље, серија RT поседује систем за подизање на стражњој шасији, који може подизати на велике висине од једног метра па више, а који лако прочишћава откосе док ради или се окреће на површини. Ове карактеристике и посебна брига за сваку појединог уз ненадмашну поузданост, изведбу и квалитет, чине серију RT јединим правим избором за професионалце који не могу дозволити себи компромисе при извршавању жетве и квалитетном обрађивању својих усева.

suspension system for: RT 730 - RT 630

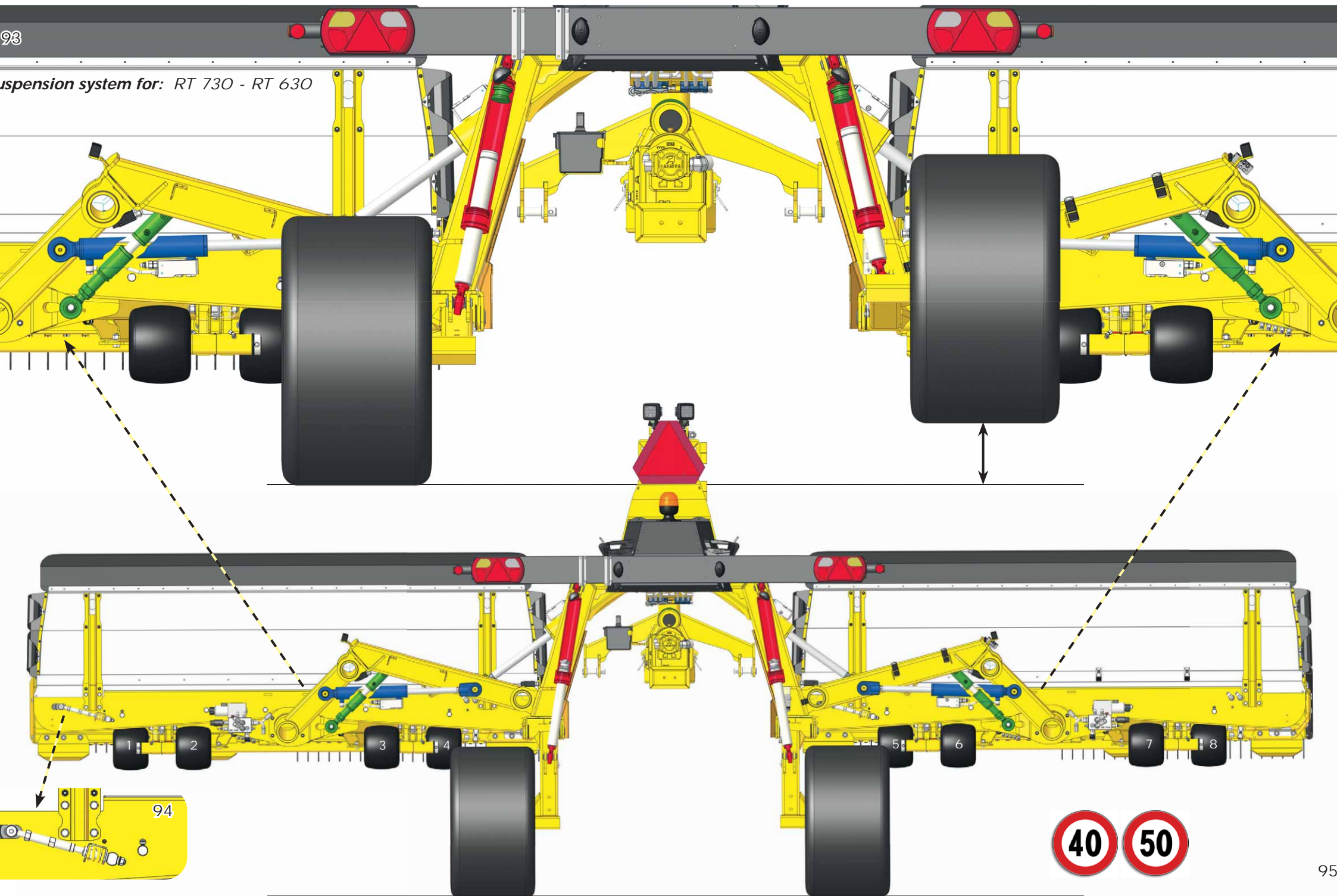

94



96 *Suspension system for: RT 1220 - RT 1000
RT 950 RT 870 - RT 810*

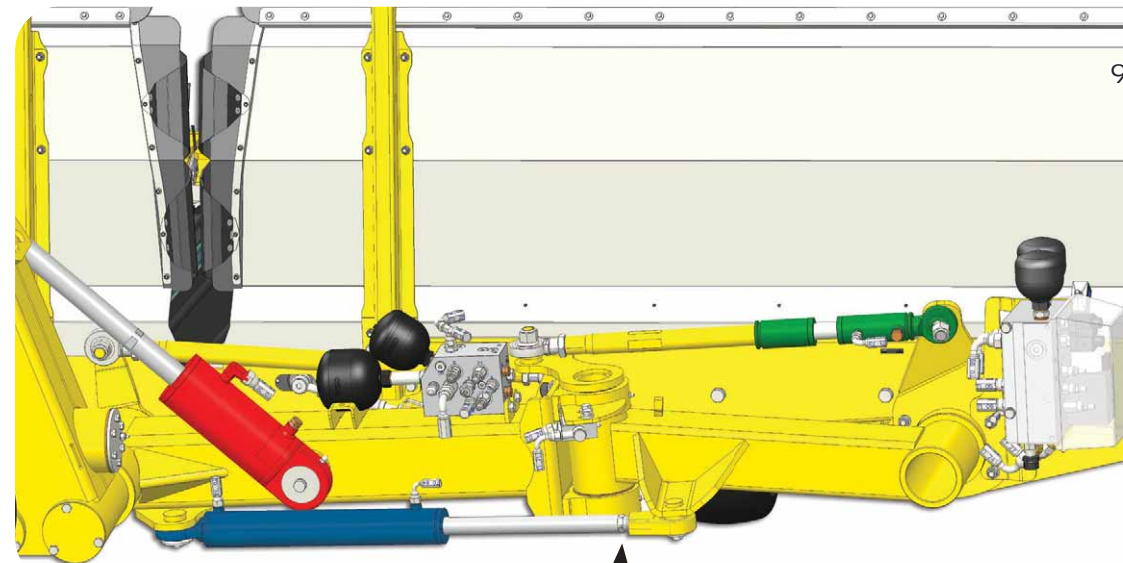
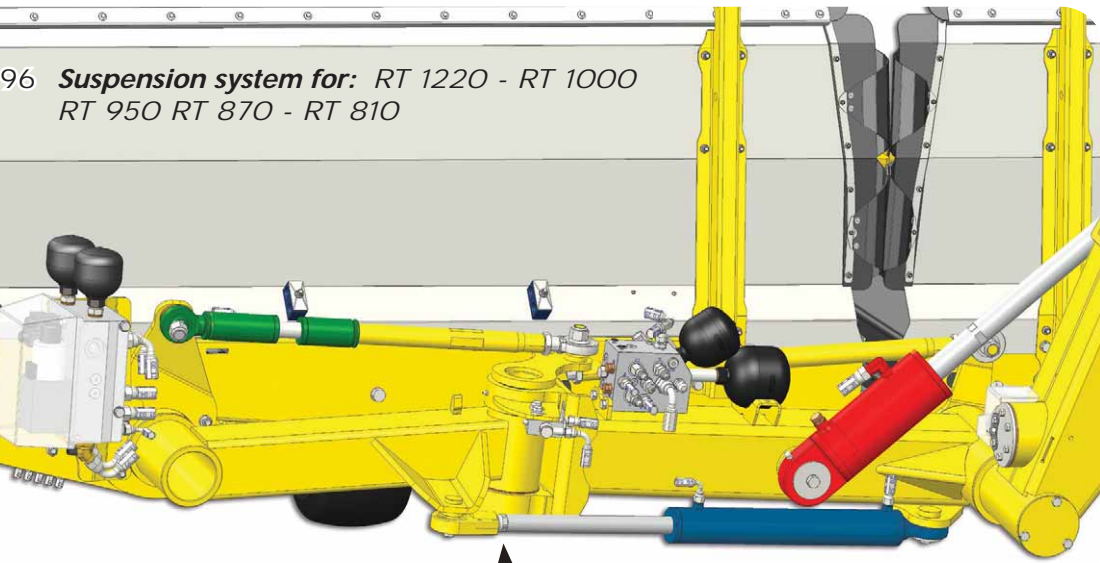

1,
99

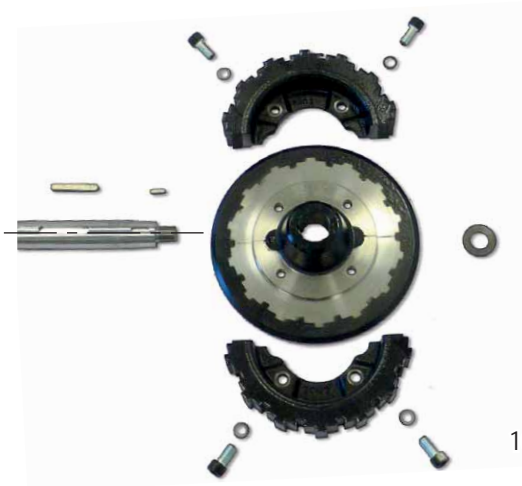
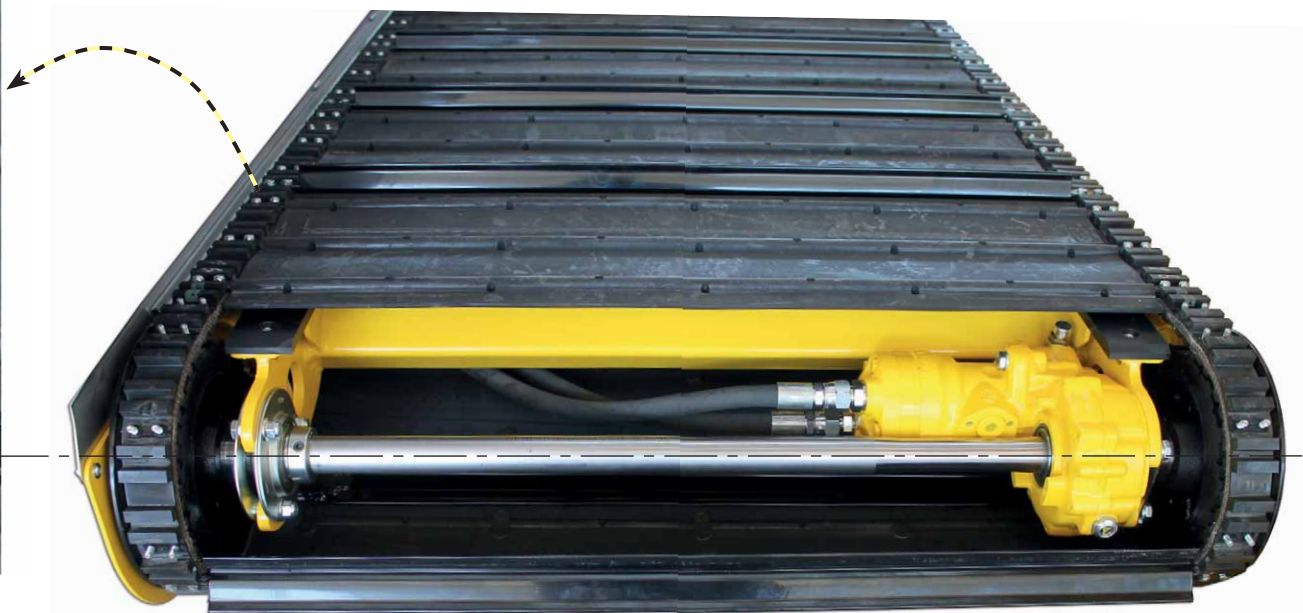

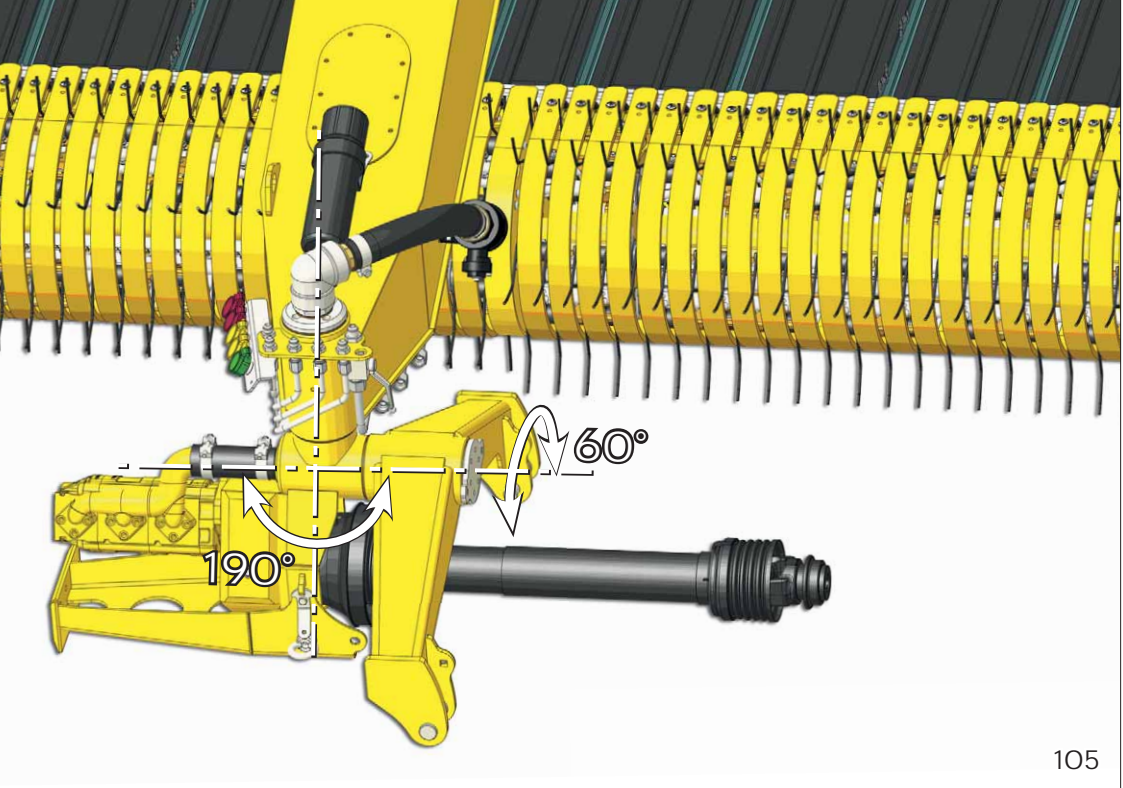

105

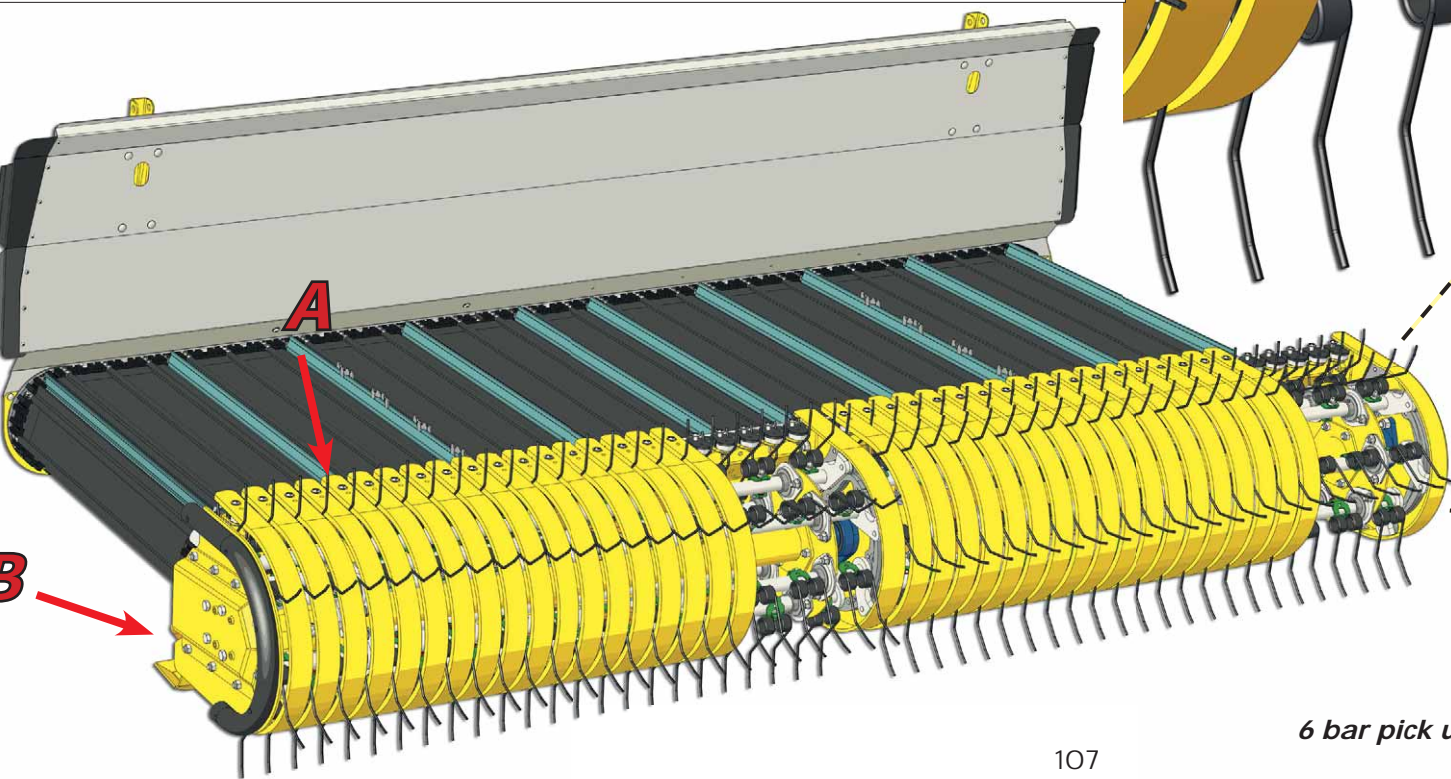

107

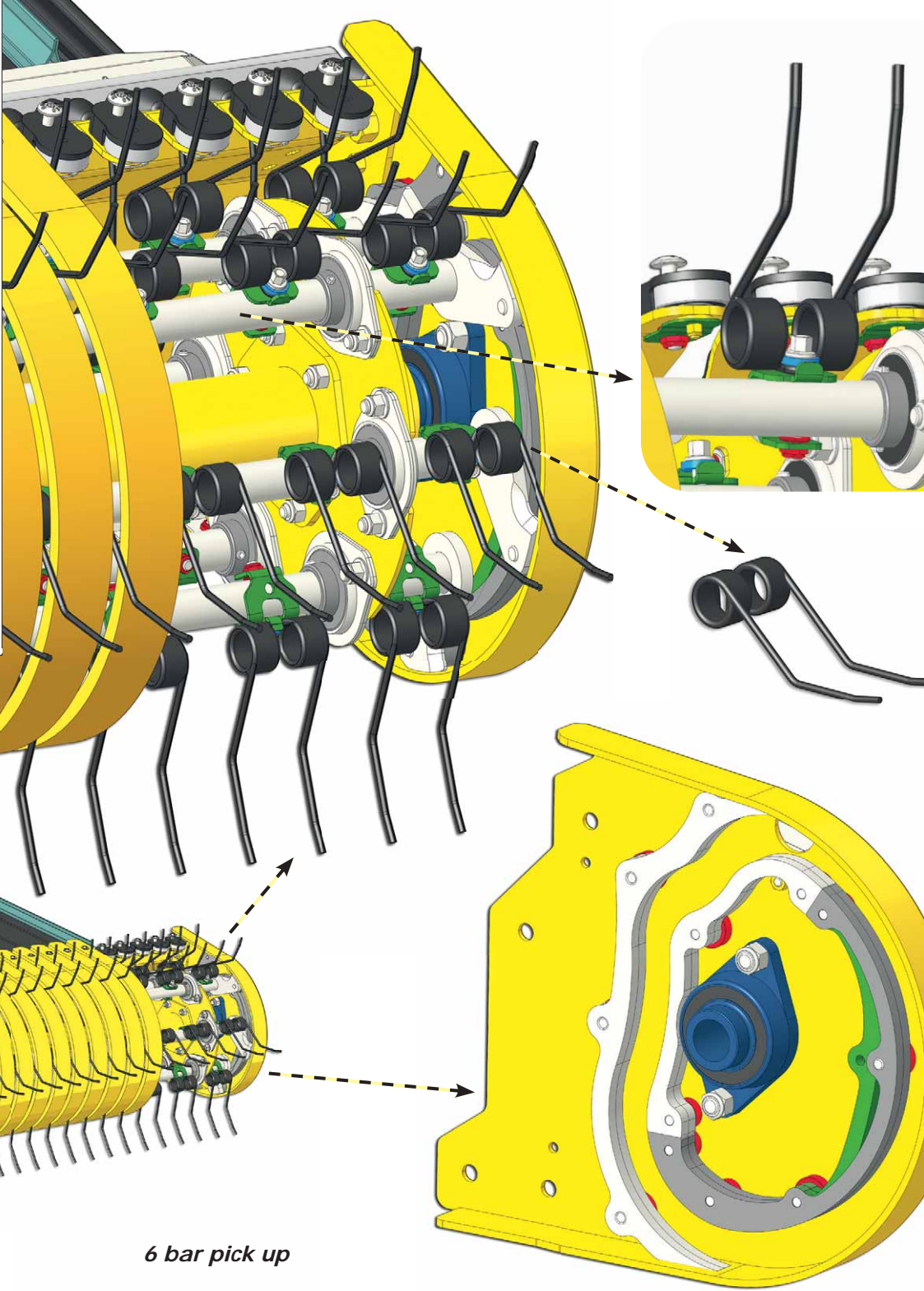

6 bar pick up

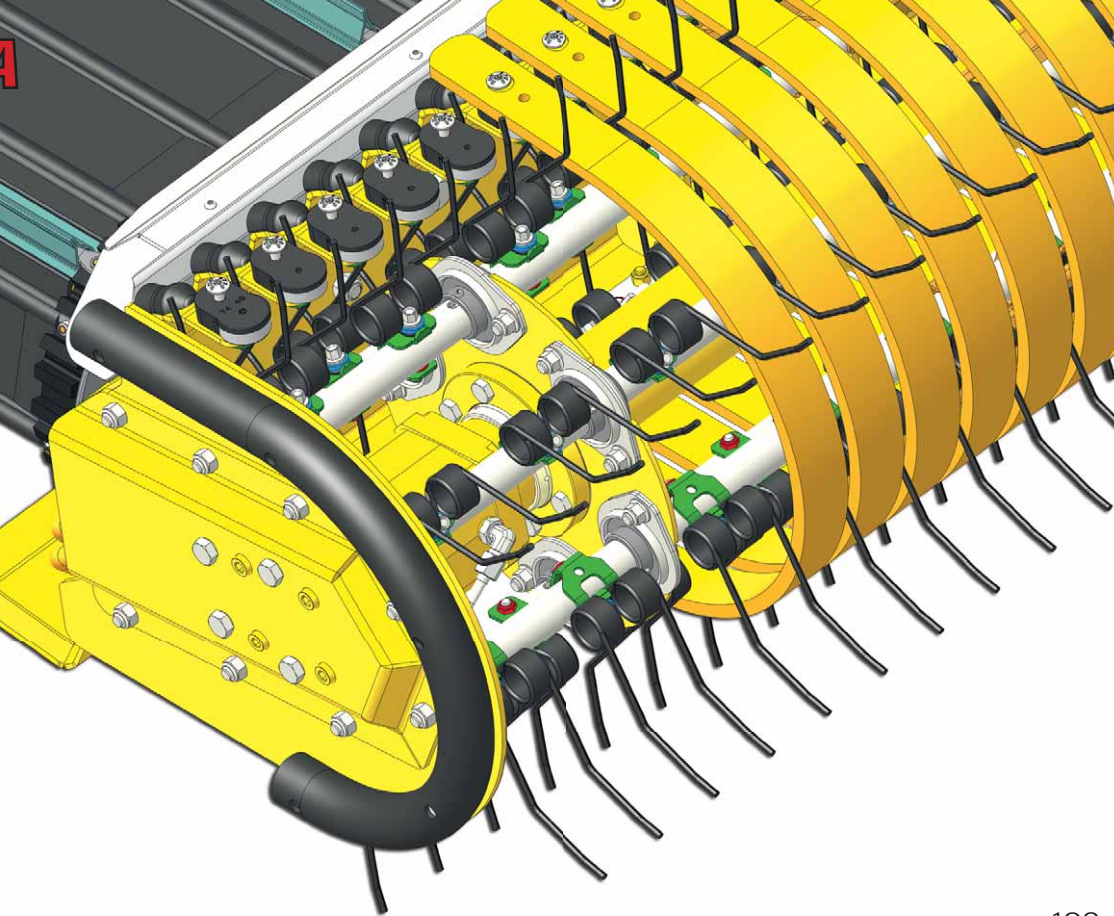

109

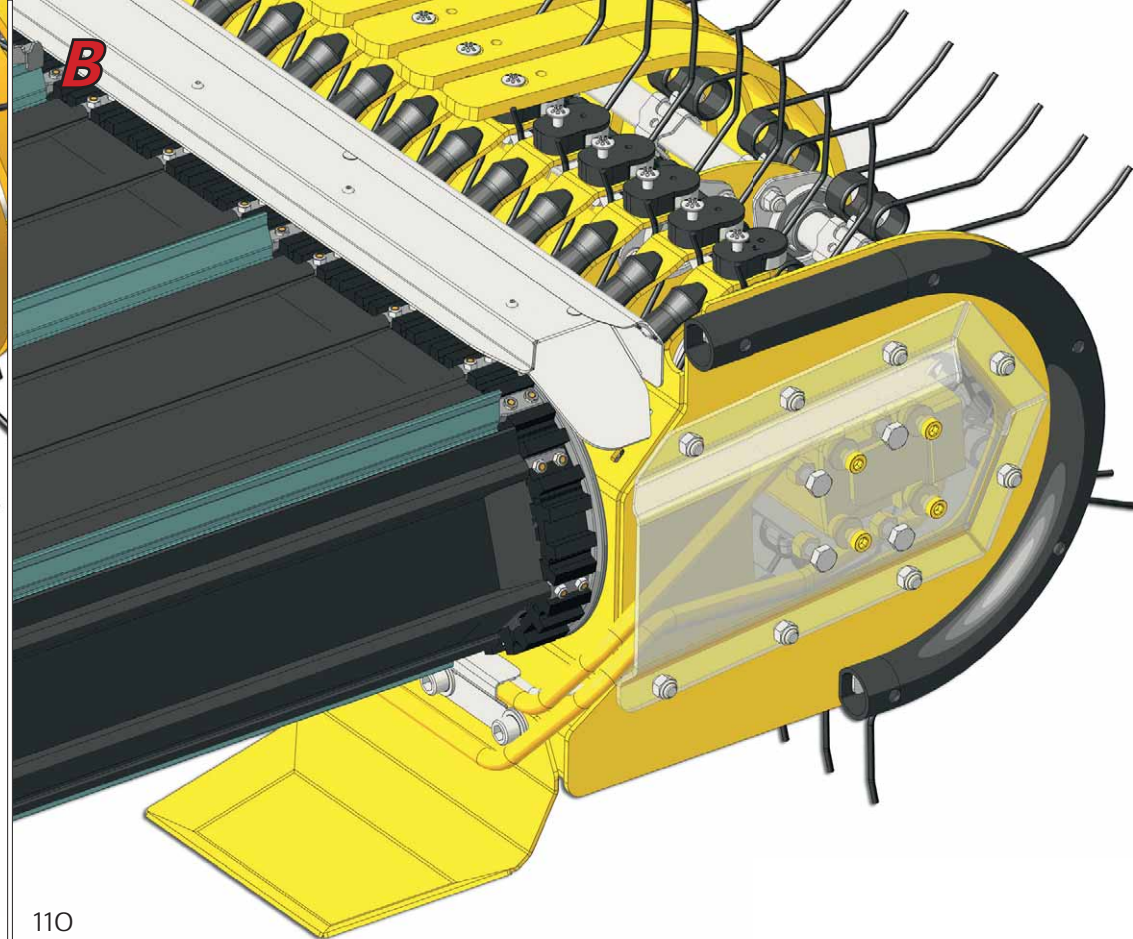

110

OPTIONAL

111

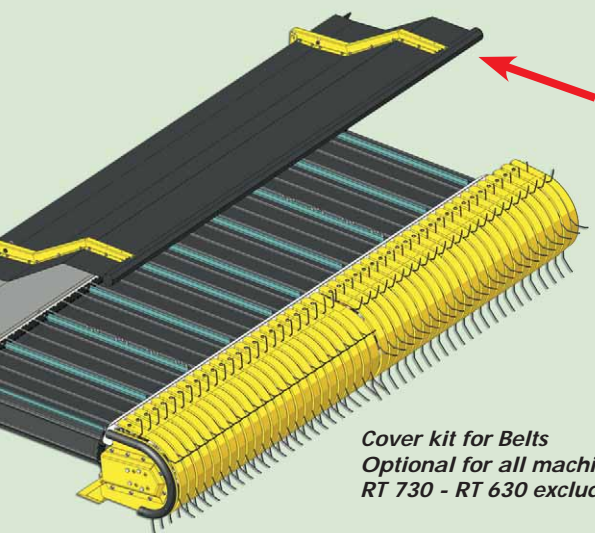

*Cover kit for Belts
Optional for all machines
RT 730 - RT 630 excluded*

OPTIONAL

112



*Automatic grease system
Optional for all trailed models*

OPTIONAL

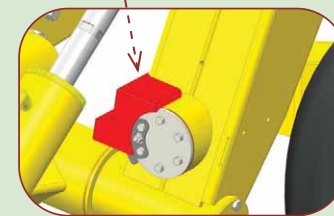

*Automatic and Manual Switch off Belts
Optional for all trailed models*

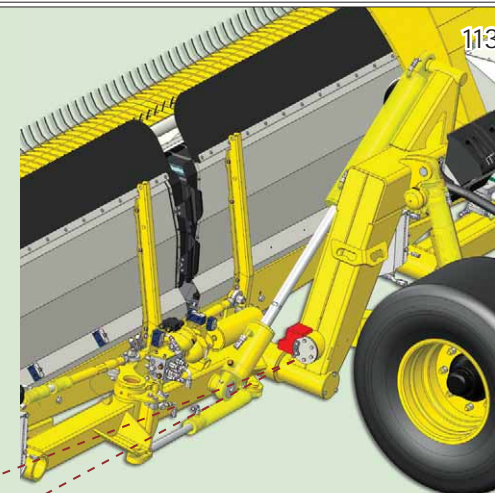

113

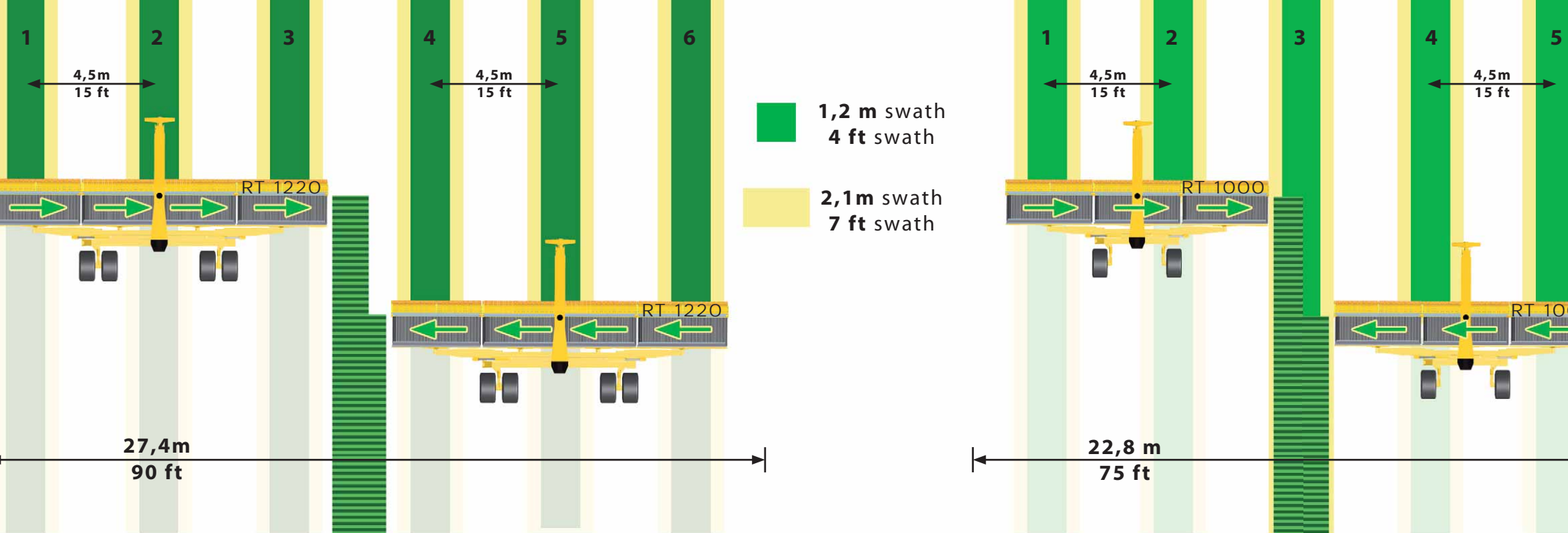

swathing example with 15 ft mower

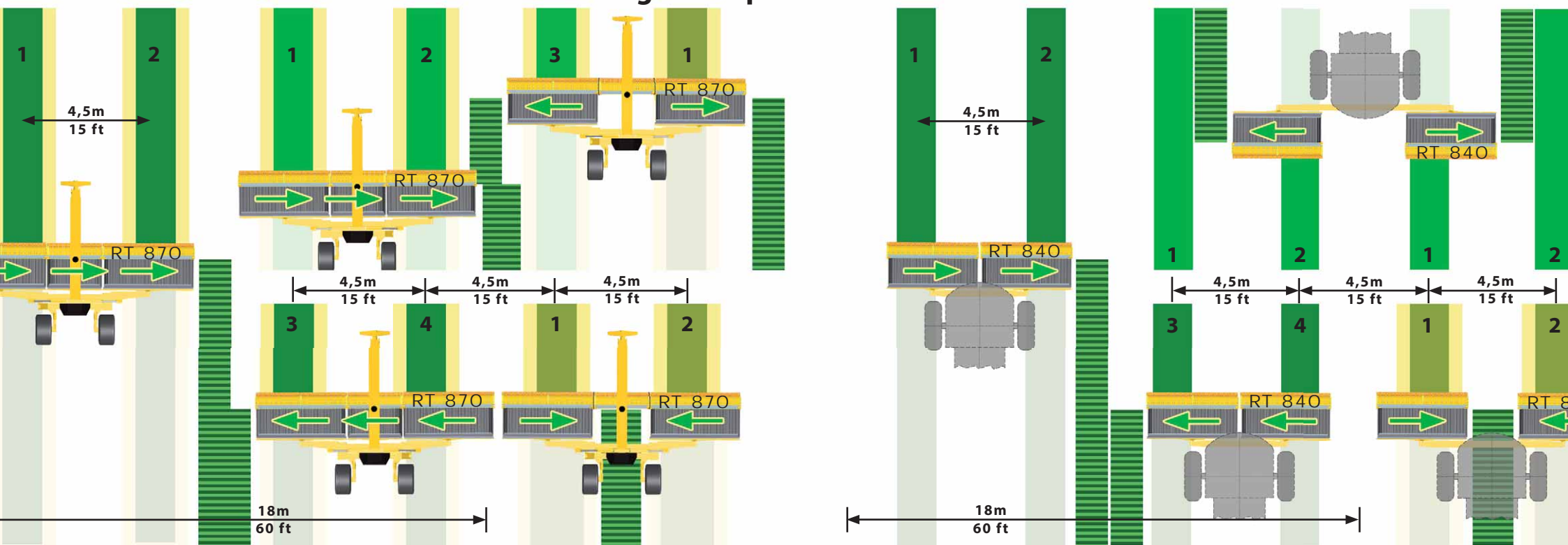

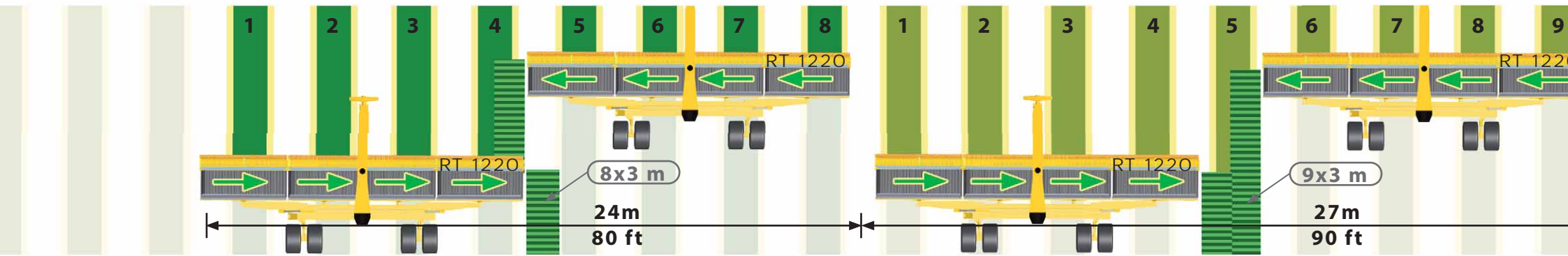
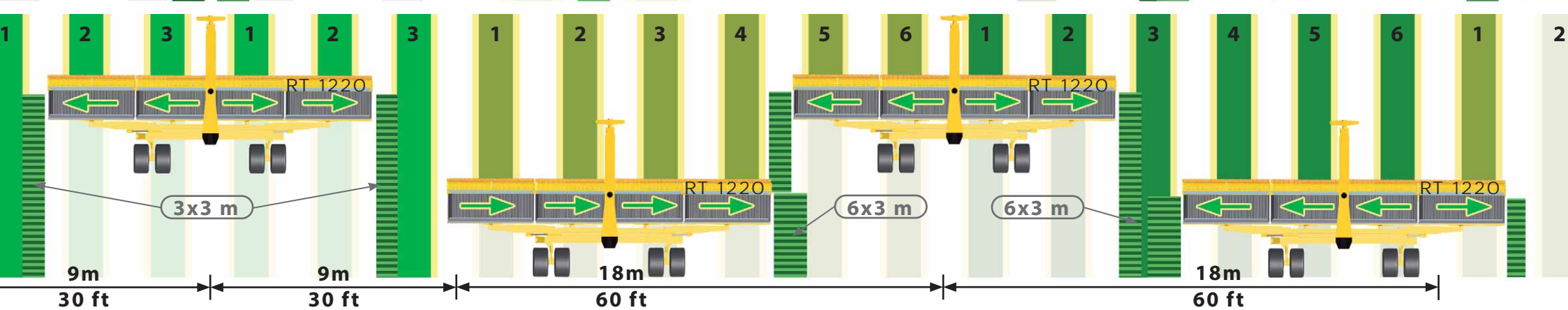
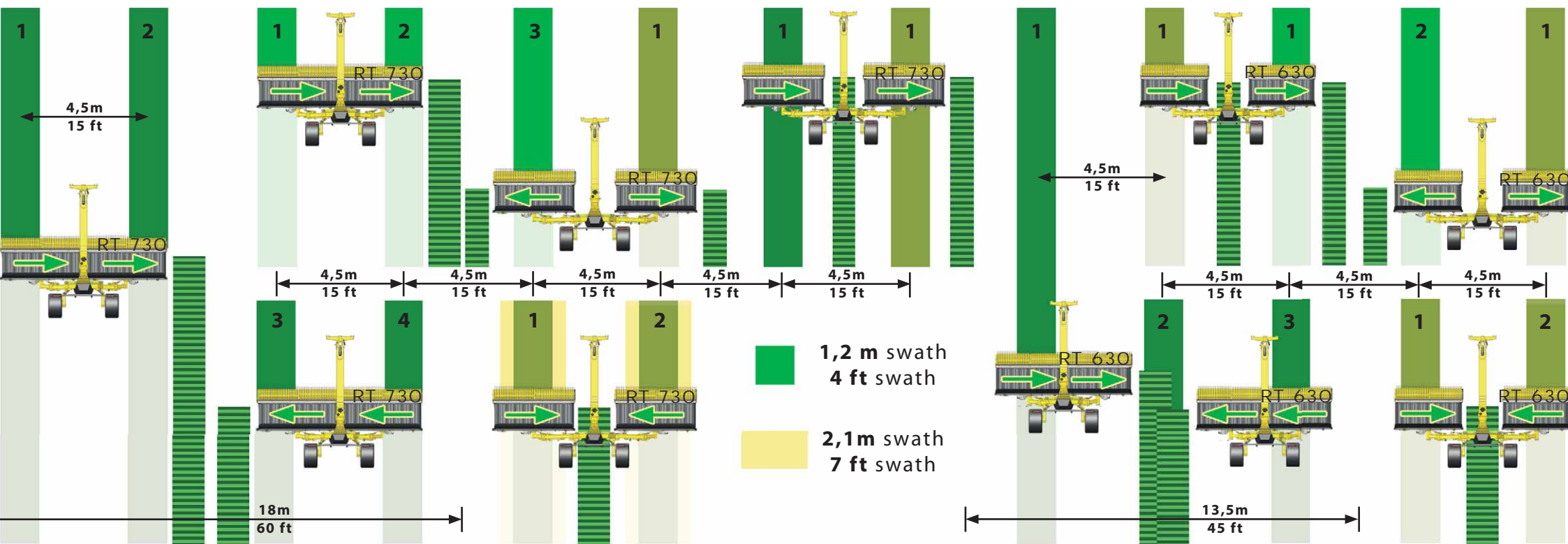

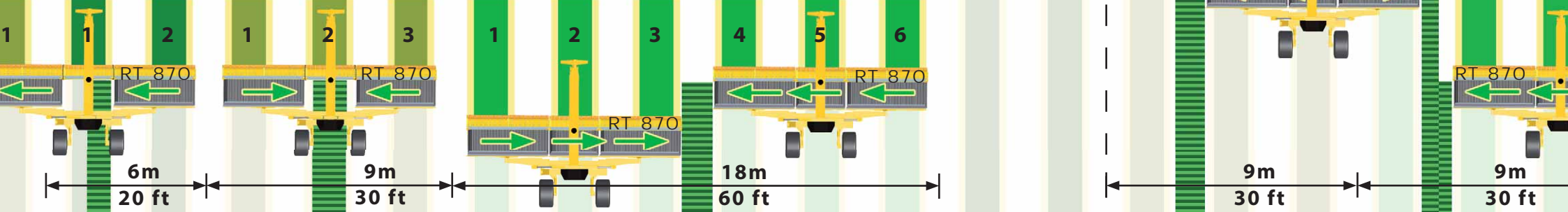
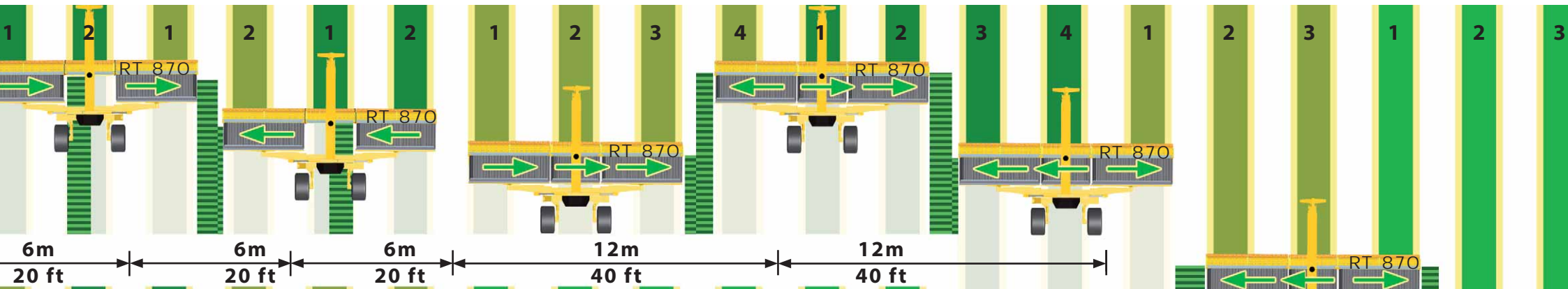
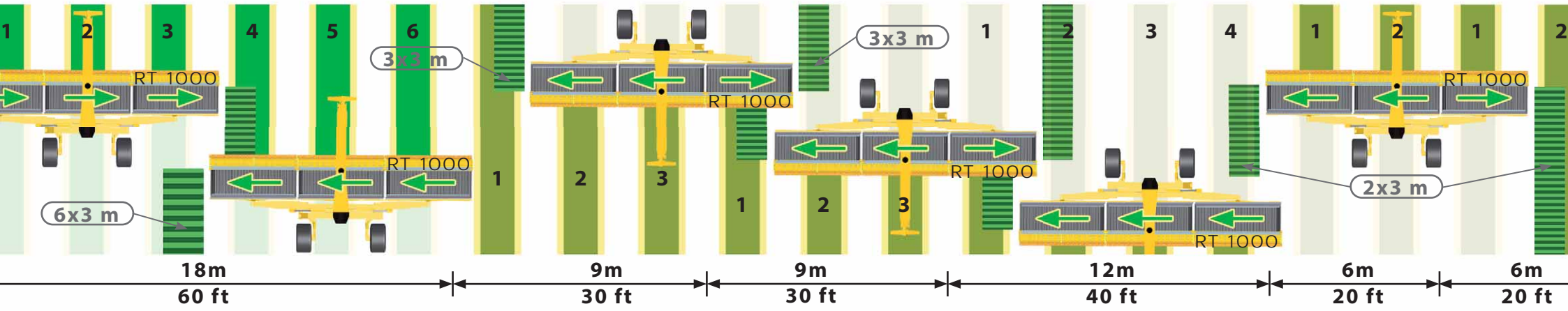
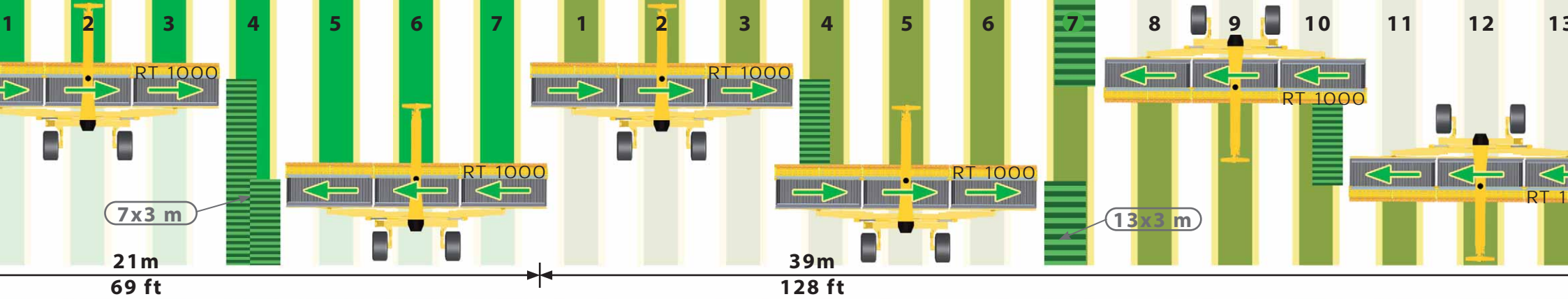

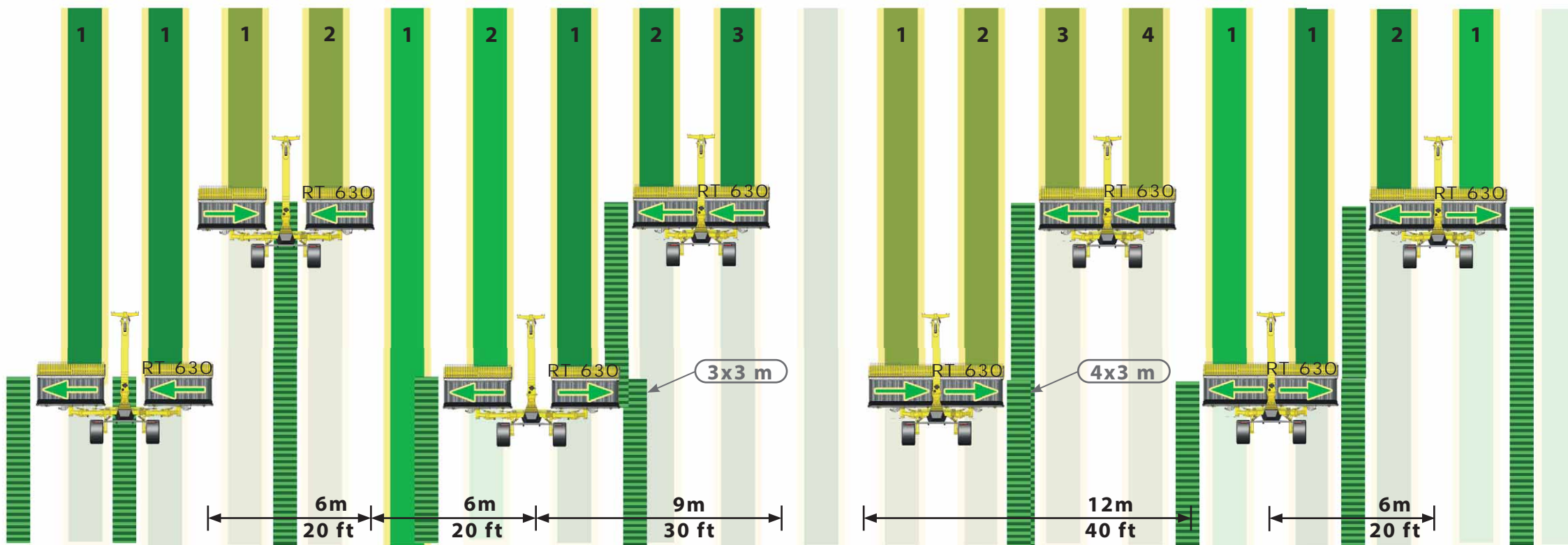
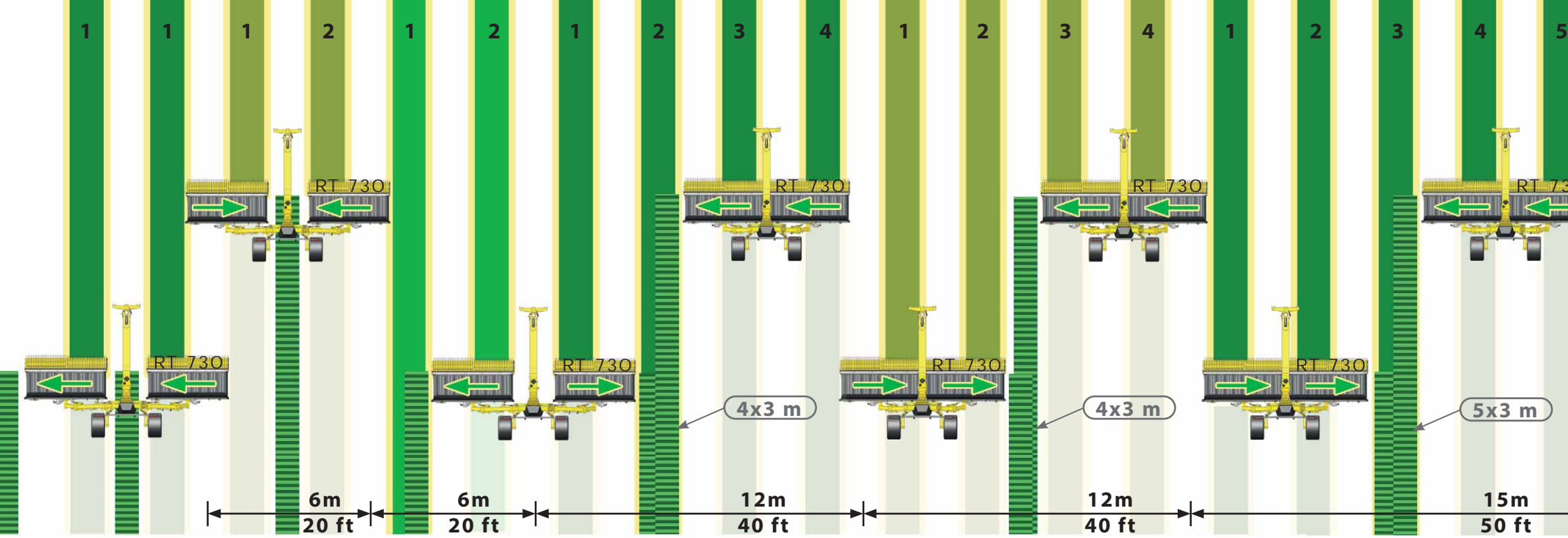

RT 1220

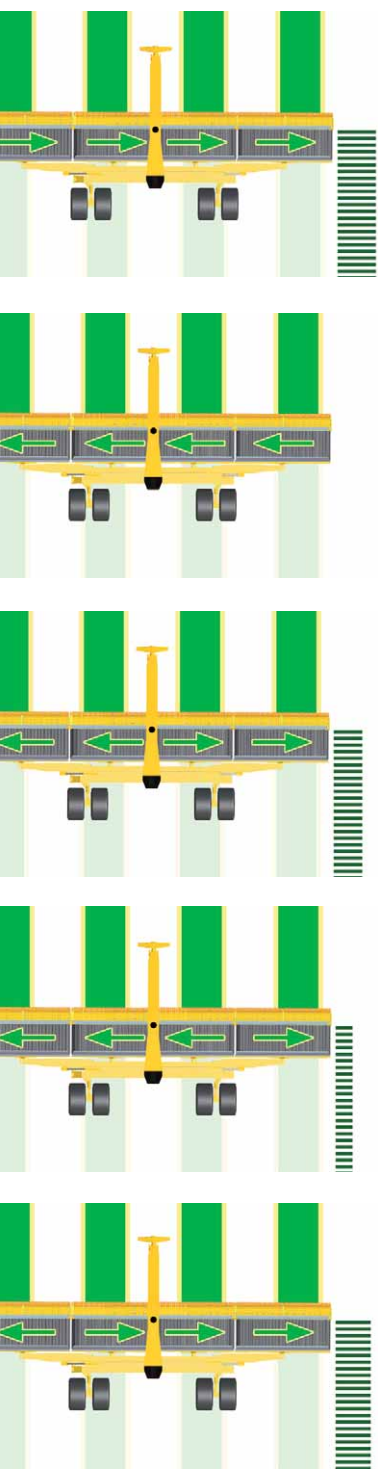

RT 1150

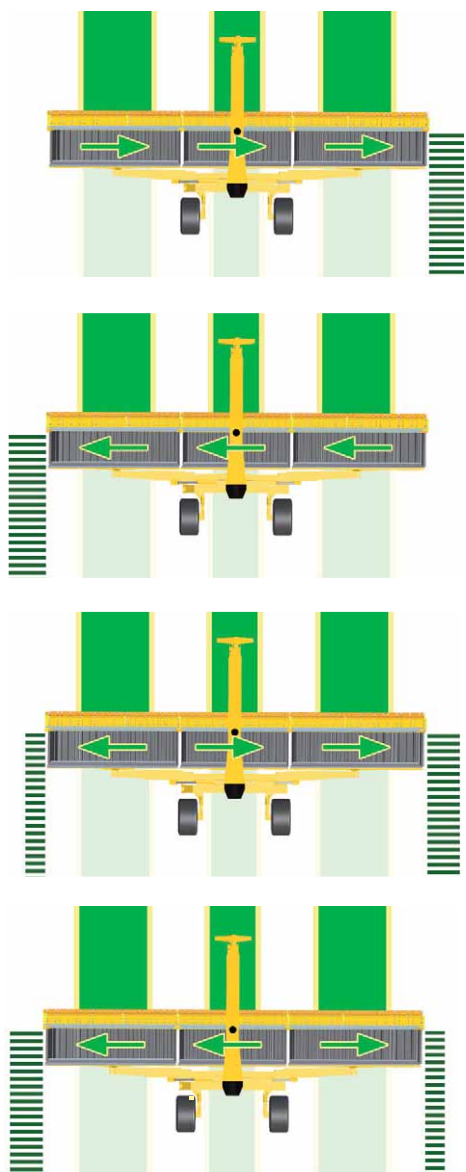

RT 1000

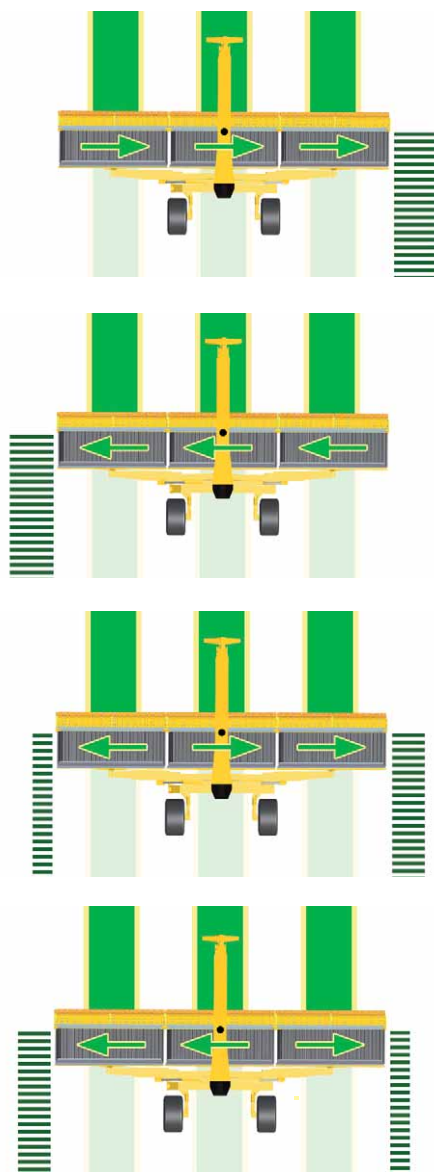

RT 950

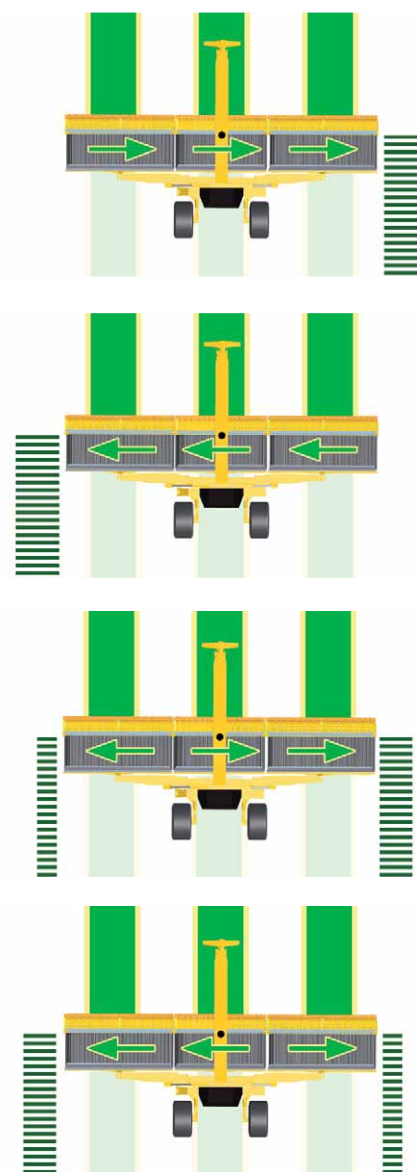

RT 870

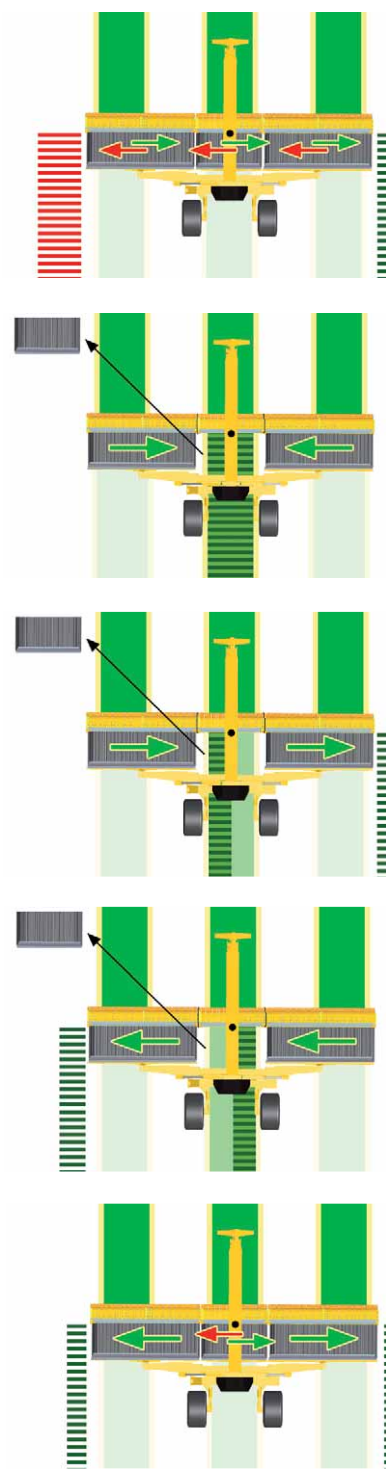

*I dati tecnici nelle raffigurazioni del
dépliant sono informativi e non impegnativi.
Les données techniques dans les images du les
dépliant sont d'information et pas compromettantes.
The technical data in the representations on the
brochure are for information and not binding. Die
technischen Angaben in dem Prospekt sind in-
formative aber nicht verbindliche Erklärungen.*

RT 840

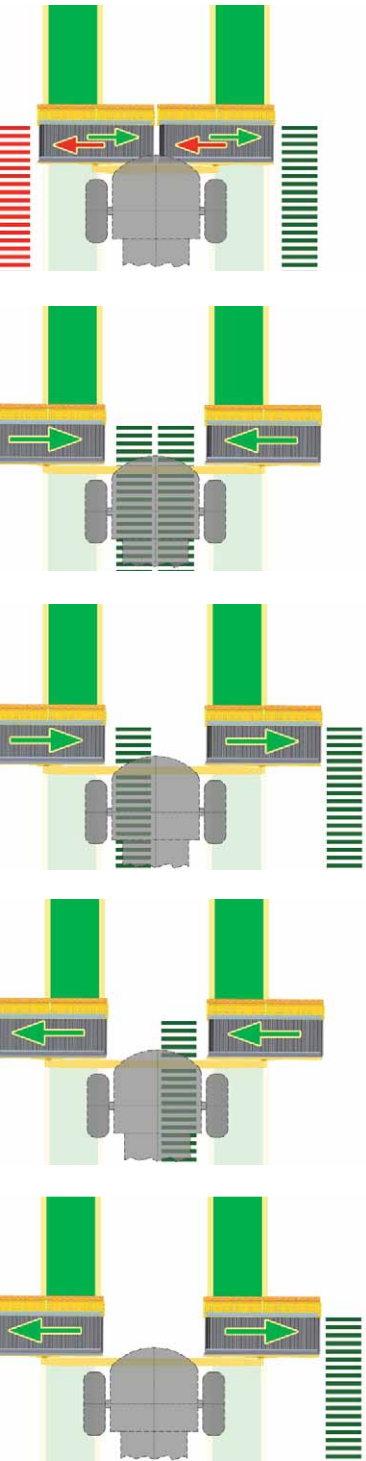

RT 880

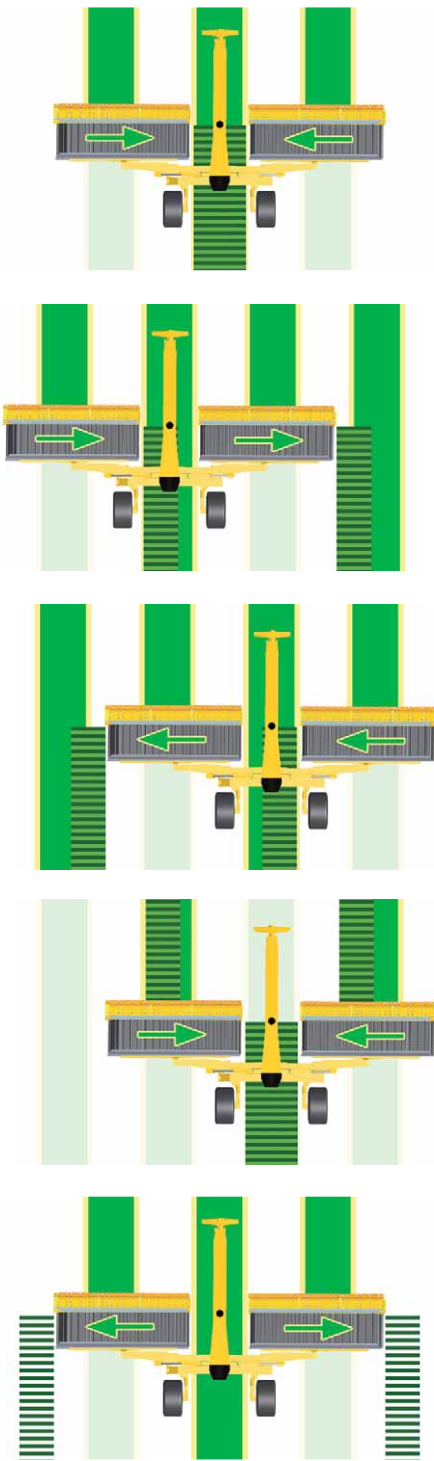

RT 730

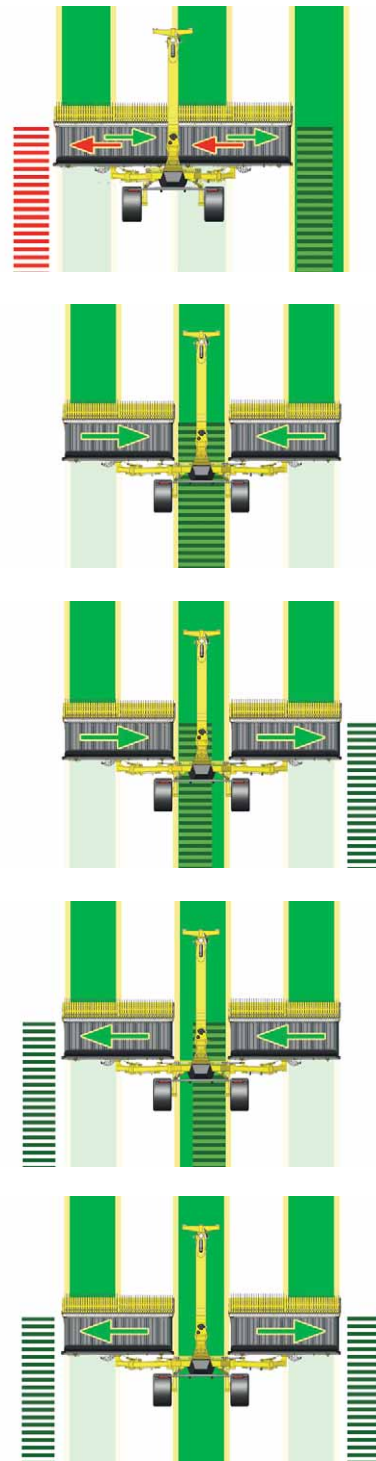

RT 630

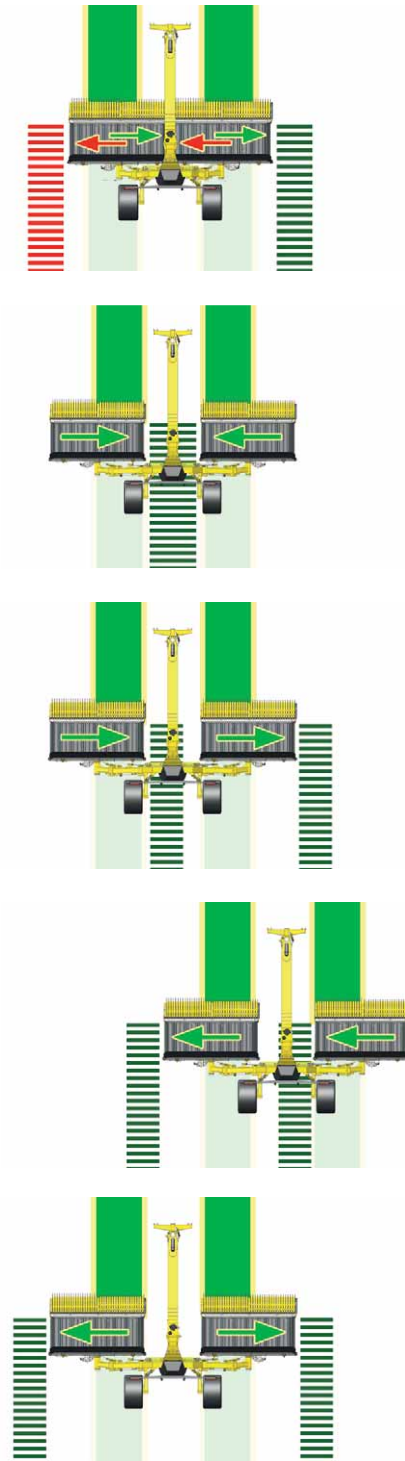

RT 1220

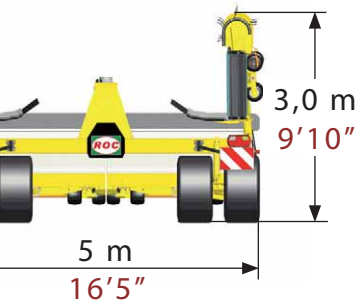
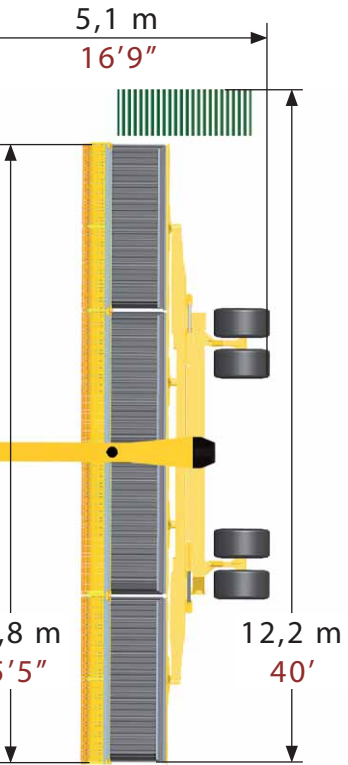

 5990 kg
13205 lb

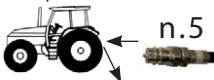
 min.power
100 hp
75 kw

 n.5
60 l/min 16 gpm

 520/50 R17

RT 1150

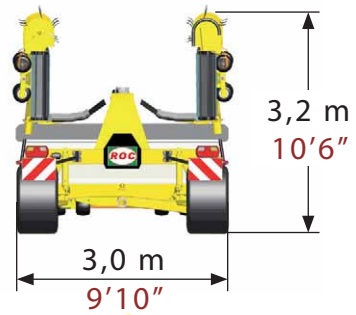
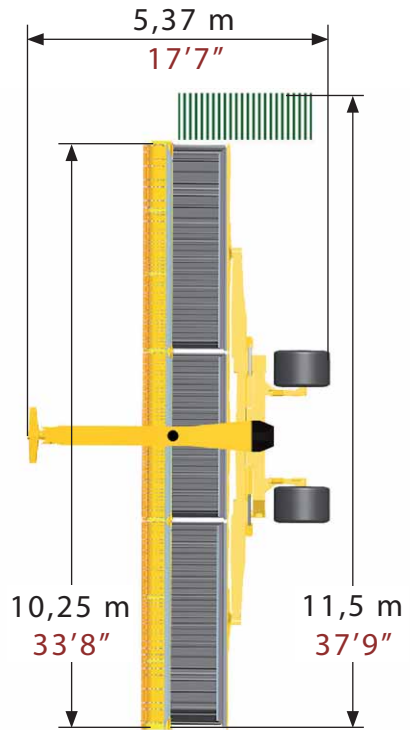

 6340 kg
13977 lb

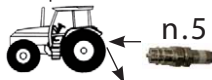
 min.power
100 hp
75 kw

 n.5
60 l/min 16 gpm

 650/40 R22,5
500/45 R22,5

RT 1000

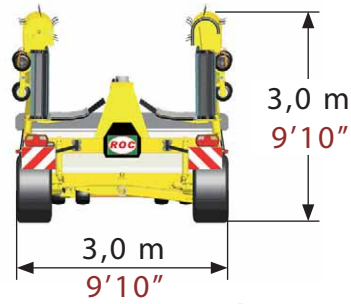
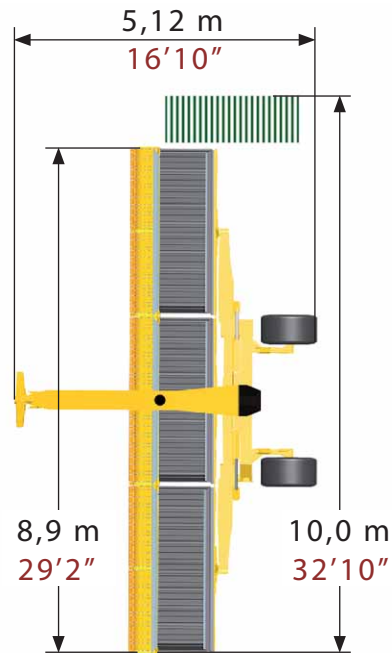

 4980 kg
10980 lb

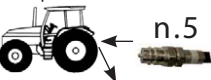
 min.power
90 hp
67 kw

 n.5
60 l/min 16 gpm

 520/50 R17

RT 950

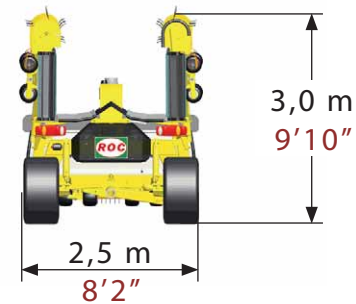
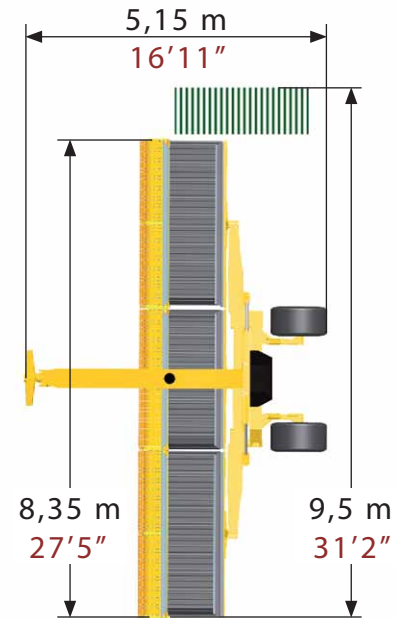

 4780 kg
10538 lb

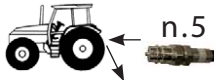
 min.power
90 hp
67 kw

 n.5
60 l/min 16 gpm

 520/50 R17

RT 870

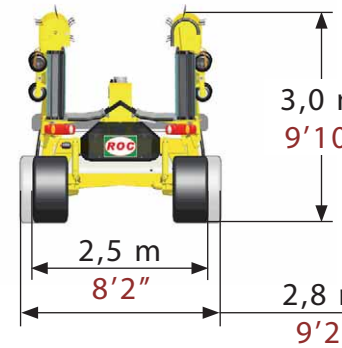
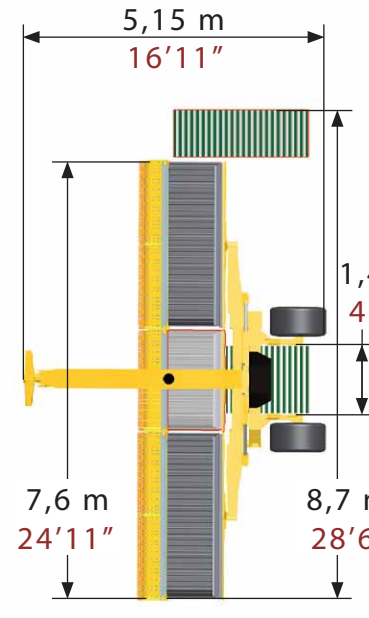

 4440 kg
9788 lb

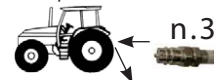
 min.power
80 hp
60 kw

 n.3
60 l/min 16 gpm

 520/50 R17
15.070 18 148

RT 840

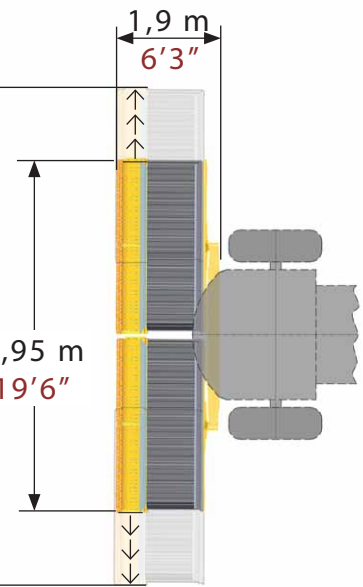

8,95 m → 8,35 m
29'6" → 27'5"



2290 kg
5048 lb

*...i tecnici nelle raffigurazioni del
...t sono informativi e non impegnativi.
...onnées techniques dans les images du les
...t sont d'information et pas compromettantes.
...chnical data in the representations on the
...e are for information and not binding. Die
...ischen Angaben in dem Prospekt sind in-
...ve aber nicht verbindliche Erklärungen.*

RT 880

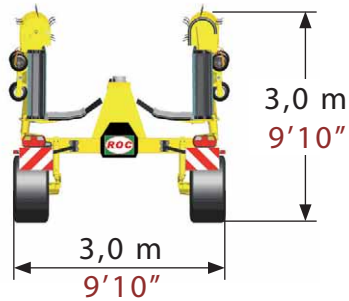
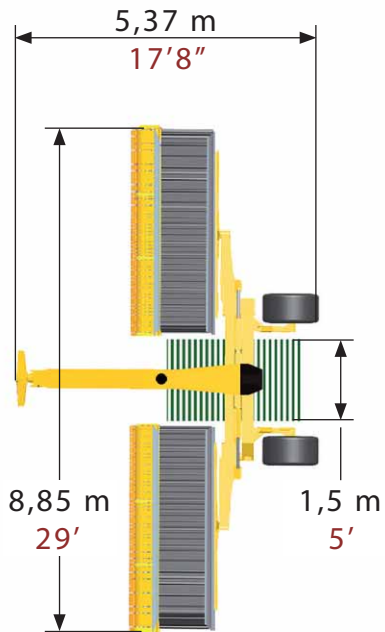

4950 kg
10912 lb

80 hp min.power
60 kw ← n.5
60 l/min 16 gpm

500/45 R22,5

RT 730

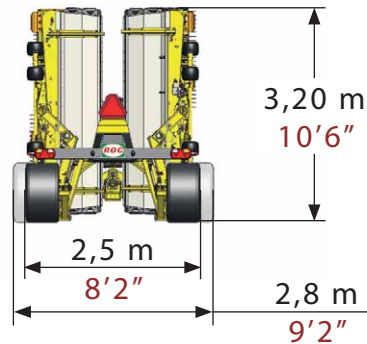
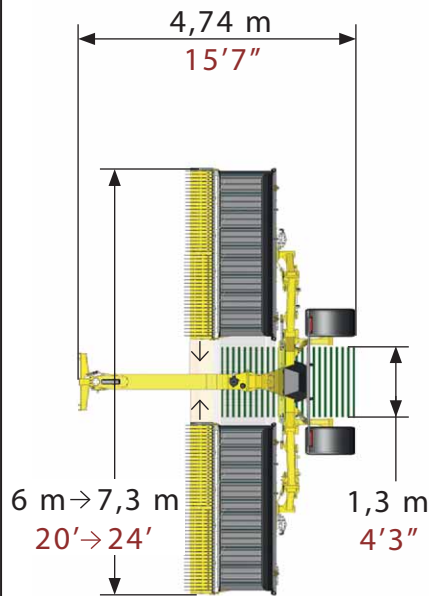

3180 kg
7010 lb

70 hp min.power
52 kw ← n.3
50 l/min 13 gpm

480/45 R17

RT 630

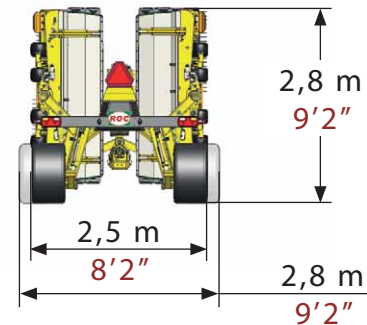
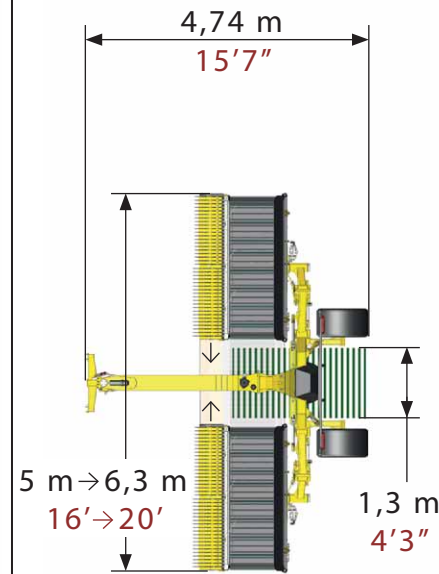

2950 kg
6503 lb

70 hp min.power
52 kw ← n.3
50 l/min 13 gpm

480/45 R17

RT 380

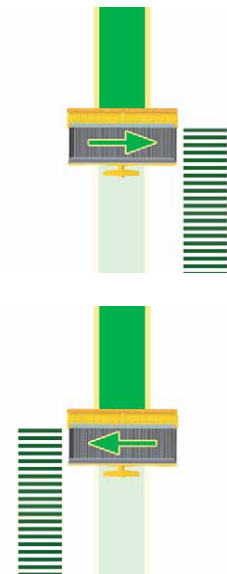
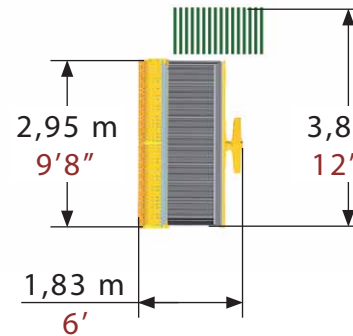

890 kg
1962 lb

60 hp min.power
45 kw ← n.3
34 l/min 9 gpm



The main ROC customer is the biggest dryer plant in the world and it's located in France. This industry works with 14 ROC mergers and makes with them 22.000 ha of alfalfa 4-5 times per year.



 **Jens Lubeck**
Agro ApS

Østergade 65
9560 Hadsund
Telefon 70 70 76 39
info@jenslubeck.dk

